



QUEENSTOWN
LAKES DISTRICT
COUNCIL



SOUTHERN LIGHT

PART TWO – TECHNICAL SPECIFICATIONS

Queenstown Lakes District Council

Date: March 2022



DRAFT

Document History	Date	Prepared By	Reviewed By	Approved
Council Adopted	9/2/2017	Alison Tomlinson/ Polly Lambert (QLDC) and Ian Campbell (Stantec)	David Wallace	Ulrich Glasner
Page 15 – clarification of NEMA socket	2/8/2017	Alison Tomlinson	Andrew Edgar	David Wallace
Clarification and update to new standards	16/05/2019 31/01/2022	Ian Campbell (Stantec) Luke Steggles (WSP) and Alison Tomlinson (QLDC)		

DRAFT

CONTENTS

1. INTRODUCTION.....	7
2. scope 8	
3. Street Lighting on Private Roads.....	8
4. APPLICABLE STANDARDS AND REGULATIONS.....	8
5. DESIGN REQUIREMENTS.....	10
6. Light Sources and Adverse Lighting Effects	10
7. Lighting Categories	11
8. Lighting Categories and the DistriCt pLAN.....	12
9. Lighting Categories p-category	12
10. Lighting Categories vehicular traffic routes.....	13
11. Lighting Categories car parks.....	14
12. DESIGN METHODOLOGY.....	15
Category V Design Objectives	15
Category P Design Objectives	16
Light Technical Parameters.....	16
Calculation of Light Technical Parameters.....	17
Maintenance Factor	17
Design Output Deliverables	18
13. Local area traffic management (latm) devices	20
14. Bus stops.....	20
15. flag lighting	20
16. Innovation and lighting trials.....	21
17. Temporary construction lighting	21
1.17.i Minimum requirements	22
1.17.ii additional requirements.....	22
1.17.iii Pedestrian walkways	22
1.17.iv exclusions	22
18. DIFFERENCES BETWEEN THE QLDC TECHNICAL SPECIFICATION AND AS/NZS STANDARDS	23
19. EQUIPMENT SELECTION AND INSTALLATION REQUIREMENTS.....	23
20. Luminaires	23
21. Lighting Columns	25
New lighting columns.....	25
22. POWER SUPPLY AND CONTROL REQUIREMENTS.....	27
23. Street Lighting Control Systems.....	30
24. COMMUNITY SPECIFIC DESIGN GUIDELINES	31
25. DESIGN GUIDELINES FOR LIGHTING NOT COVERED IN AS/NZS 1158.....	31
26. Feature Lighting (Up-lighting and Flood Lighting)	31
27. Parks and Open Spaces.....	33
28. Illuminated signs.....	33
29. private exterior lighting – non domestic	33
30. Outdoor domestic lighting.....	34
31. OPERATIONAL POLICIES.....	34
32. Street lighting Renewals	34

33. Attachments on Lighting Poles.....	34
34. Data Provision requirements Specific for Lighting and electrical installations	35
35. Post Construction Requirements.....	35
APPENDIX 1 - TYPICAL INFORMATION SHEET DRAWING	37
APPENDIX 2 - TYPICAL DESIGN NOTES AND CALCULATION RESULTS.....	38
Illuminance Calculation results (exported from AGi32):.....	38
APPENDIX 3 – Lighting Column Power Supply and Electrical Details	39
APPENDIX 4 - TYPICAL LAYOUT DRAWING.....	42
APPENDIX 5 - TYPICAL PERFECT LITE CALCULATION RESULTS	43
APPENDIX 6 - TYPICAL POLE DETAILS.....	44
6.1 Tapered Octagonal Steel Lighting Pole c/w Curved Outreach Arm	44
6.2 Typical Lighting Pole Foundation Details.....	45
6.3 JUMA and JUSP Signal Poles.....	46
6.4 Typical Power Pole Mounting Details.....	48
APPENDIX 7 - EXAMPLE OF COMMUNITY SPECIFIC DESIGN (CARDRONA).....	49
APPENDIX 8 – Example forms	50

DRAFT

DRAFT

1. INTRODUCTION

The purpose of this document is to ensure that lighting infrastructure in Queenstown Lakes meets the outcomes specified in the Southern Light, Part One – A Lighting Strategy. That is through providing safe environments for pedestrians, vehicles and to discourage illegal acts as well as ensuring that public lighting is attractive, robust, easy to maintain, cost effective and fit for purpose. This document will set out accepted best practice, minimum manufacturing and performance standards, as well as QLDC asset management and strategic objectives throughout the district, including QLDC vested road and outdoor lighting, private lighting and new developments, and parks and feature lighting.

This technical guide should be read in conjunction with the following which can be found on the QLDC website:

- QLDC District Plan.
- Southern Light, Part One – A Lighting Strategy
- QLDC Land Development and Subdivision Code of Practice

This document shall be used by developers, contractors, consultants, service/utility operators, QLDC design engineers, planners, project managers and others involved in the design, installation and management of new lighting installations. It may be used as a guide to repair or replace existing lighting infrastructure.

It is acknowledged the District has community specific urban design requirements and these will be referenced individually.

In summary this document describes how to complete the detailed design and calculations required for compliance with the applicable standards to achieve the following:

- Provision of vehicular route lighting for vehicle and pedestrian safety
- Provision of pedestrian route/area lighting for pedestrian safety, crime prevention and to enhance the environment
- Provision of lighting infrastructure (luminaires, columns, outreach arms, bracket arms and associated equipment) that is energy efficient, cost effective and will cope with regional climatic and environmental conditions such as extreme temperatures and weather conditions
- Provision of feature and festive lighting (whether temporary or permanent) that do not create excessive glare or spill light into neighbouring properties. Exemptions must be granted by QLDC where this lighting contravenes Southern Light.
- While achieving safe and compliant lighting (as described above) also minimising any negative impacts such as obtrusive (spill) light, glare, and light pollution (upward waste light contributing to sky glow)

Southern Light is a live document subject to periodic review and may be amended at any time as and when directed by QLDC.

2. SCOPE

The main scope of this document includes areas covered by the AS/NZS 1158

- Roads, accessways and rights of way (public & private)
- Reserves and public activity areas
- Pedestrian (Zebra) crossings
- Pedestrian and cycle paths
- Public precincts (e.g., shopping precincts)
- Public access areas (e.g., connecting elements including steps, ramps, subways, footbridges and CCTV)
- Car parks
- Bus stops
- Bike stands and transport hubs
- Vested infrastructure such as pumpstations, reservoirs, treatment plant sites

This document also provides indicative design guidelines for areas outside AS/NZS 1158 which includes, but not limited to

- Parks and Reserves and sports fields
- Illuminated Signs
- Feature Lighting (up-lighting & spot lighting)

Guidelines for exterior lighting can be found in AS/NZS 1680, AS/NZS 2293 and the NZ Building Code. Guidelines for sports lighting (interior/exterior) can be found in AS 2560.

3. STREET LIGHTING ON PRIVATE ROADS

QLDC's policy for street lighting on private roads encompasses the following:

- Maintenance and operating costs of lights installed on private roads and rights of way after 01 January 2004 shall be the responsibility of lots serviced by such private access roads; and
- All lights installed on private roads, accessways and Rights of Way after 01 January 2004 shall be isolated from the QLDC lighting network.
- Refer Section 33 for guidance on technical considerations.

4. APPLICABLE STANDARDS AND REGULATIONS

The following section lists the standards and regulations applicable to the design, installation, and maintenance of road lighting installations. The latest copies of standards and their amendments shall apply.

Professional Practice and Design:

Engineering New Zealand Practice Note 1 – Guidelines on Producer Statements

Engineering New Zealand Practice Note 2 – Peer Review

Health and Safety at Work Act 2015 (HSW Act)

Safety in Design:

Guide to Health and Safety by Design

Electrical:

The Electricity Act 1992

The Electricity (Safety) Regulations 2010

The NZ Electrical Codes of Practice

The NZ Building Code

AS/NZS 3000: Electrical installations (known as the Australian/New Zealand Wiring Rules)

Lighting:

AS 2560 (Series): Sports lighting

International Dark Sky Association IDA-Criteria for Community-Friendly Outdoor Sports Lighting

AS/NZS 4282: Control of the obtrusive effects of outdoor lighting

AS 60529: Degrees of protection provided by enclosures (IP Code)

AS/NZS 1158.0: Lighting for roads and public spaces, Part 0: Introduction

AS/NZS 1158.1.1: Lighting for roads and public spaces, Part 1.1: Vehicular traffic (Category V) lighting - Performance and design requirements

AS/NZS 1158.1.2: Lighting for roads and public spaces, Part 1.2: Vehicular traffic (Category V) lighting - Guide to design, installation, operation and maintenance

AS/NZS 1158.2: Lighting for roads and public spaces, Part 2: Computer procedures for the calculation of light technical parameters for Category V and Category P lighting

AS/NZS 1158.3.1: Lighting for roads and public spaces, Part 3.1: Pedestrian area (Category P) lighting - Performance and design requirements

AS/NZS 1158.4: Lighting for roads and public spaces, Part 4: Lighting of pedestrian crossings

AS/NZS 1158.5: Lighting for roads and public spaces, Part 5: Tunnels and underpasses

AS/NZS 1680 (Series): Interior and workplace lighting

AS/NZS 2293 (Series): Emergency escape lighting and exit signs for buildings

AS/NZS 60598.2.3: Luminaires - Particular requirements - Luminaires for road and street lighting

SA/SNZ TS 1158.6: Lighting for roads and public spaces - Luminaires - Performance

BS 5489-1: Code of practice for the design of road lighting, Part 1: Lighting of roads and public amenity areas

IEC 62262, Ed. 1.0: Degrees of protection provided by enclosures for electrical equipment against external mechanical impacts (IK code)

NZTA M30: Specification and Guidelines for Road Lighting Design

Refer to the International Dark Sky Association (IDA) for general information and guidelines

Lighting poles (design and construction):

NZTA M26: Specification for Lighting Columns

5. DESIGN REQUIREMENTS

The applicable design standards shall be the New Zealand requirements of the AS/NZS 1158 series, and the following sections provide a summary of the main requirements. The designer shall be responsible for applying all the specific design requirements of AS/NZS 1158 (as well as any other QLDC specific rules or procedures) to the extent they are applicable whether or not they are included in this document.

Safety in Design

The HSW Act requires persons controlling a business or undertaking (PCBUs) to ensure so far as is reasonably practicable the health and safety of their workers and workers whose work is influenced or directed by the PCBU. PCBUs must also ensure that the health and safety of other persons is not put at risk as a result of their activities. Part of this duty involves the PCBU eliminating or minimising risks arising from work.

PCBUs, which design plant and structures that are to be used, or could reasonably be expected to be used, in a workplace, have a duty to ensure so far as is reasonably practicable that the plant or structure is designed to be without risks to H&S.

Section 22 of the HSW Act defines 'Reasonably Practicable' as something which is, or was, at a particular time, reasonably able to be done in relation to ensuring health and safety, considering and weighing up all relevant matters including:

- The likelihood of the hazard or the risk concerned occurring;
- The degree of harm that might result from the hazard or risk;
- What the person concerned knows, or ought reasonably to know, about the hazard or the risk and the ways of eliminating or minimising the risk;
- The availability and suitability of ways to eliminate or minimise the risk; and
- That after assessing the extent of the risk and the available ways of eliminating or minimising the risk, the cost associated with available ways of eliminating or minimising the risk, including whether the cost is grossly disproportionate to the risk. A SID process aims to address the above matters by designing out safety risks where it is reasonably practicable to do so.

The designer must prepare a Safety in Design (SiD) register and supply as part of the design when presented for review. This shall encompass all assessed Health and Safety considerations created by the design provided for review.

The SiD register integrates hazard identification and risk assessment methods in the design process. It must demonstrate how to eliminate, isolate or minimise the risk of death, injury and ill health to those who will construct, operate and maintain. Where additional requirements to manage uncontrolled risks identified by the designer are needed in later stages of the project, these risks shall also be highlighted and shared (by the designer) with the Principal Designer and Constructors.

6. LIGHT SOURCES AND ADVERSE LIGHTING EFFECTS

All new lighting installations shall utilise light emitting diode (LED) technology luminaires. Refer to NZTA M30 for a list of acceptable luminaires. Alternative LEDs may be considered for amenity lighting on reserves, provided they meet the minimum manufacturing, testing and performance requirements of NZTA M30 including warranty period. QLDC reserves the right to exclude any alternative LED (not on the current NZTA M30 list) if the designer or supplier cannot clearly demonstrate full compliance with NZTA M30. Other technologies may be considered and shall be confirmed by QLDC before final design is finalised.

As part of the lighting design process the designer shall consider and minimise any potential adverse or obtrusive lighting effects such as spill light, glare and sky glow (upward light). The limits of adverse lighting and methods of mitigation, as provided in AS/NZS 4282, shall be followed.

Private lighting must comply with district plan spill lighting requirements and spill lighting calculations on boundaries need to be included for these.

“No activity on any site shall result in greater than a 3.0 lux spill (horizontal and vertical) of light onto any other site measured at any point inside the boundary of the other site.”

Feature and festive lighting outside of M30 may be approved by QLDC on an individual basis. Details of wattage / energy consumption must be supplied as part of the application process.

7. LIGHTING CATEGORIES

The primary aim of any road lighting scheme is to facilitate the safe movement of people. There are two main categories of lighting (Category V and P), and various subcategories, that provide varying levels of lighting based on a number of particular traffic (vehicular and pedestrian) parameters applicable for each type of road.

Category V lighting is applicable to roads where the visual requirements of motorists are dominant e.g. arterial or main roads, motorways and sub-arterial roads.

Category P lighting is applicable to roads and other outdoor public spaces where the visual requirements of pedestrians are dominant e.g., Town Centre areas, local roads, pedestrian pathways and cycleways.

The decision to install a lighting scheme in compliance with AS/NZS 1158 (and any other QLDC policies and procedures), including which subcategory of lighting is applicable, rests with QLDC. This decision is typically based on factors such as night-time traffic flows, composition of traffic (vehicular and/or pedestrian), the need to enhance prestige, risk of crime and other patterns of use.

The designer may select and design to the light category based on the guidance below and proceed at their own risk, however, if QLDC are not in agreement with the selected Sub-Categories we reserve the right to direct the designer to change at the review stage. If there is uncertainty over the category to be used for the design, the developer shall contact QLDC to reach agreement on category, prior to commencement of design.

Note that more than one subcategory may be required within one development, e.g., different road hierarchies and car park lighting.

The designer (or nominated QLDC representative) may be required to assist in the Sub-Category evaluation process for more complex applications, in this scenario no design shall be commenced until QLDC approval has been obtained.

Reference should be made to the relevant parts of the current AS/NZS 1158 series that provide indicative guidance on the application of the different categories and subcategories of lighting. Relevant parts include:

- Figure 2.1 from AS/NZS 1158.1.1 and AS/NZS 1158.3.1 - Example Road and Public Space Types and Indicative Lighting Categories and Subcategories
- Table 2.1 from AS/NZS 1158.1.1 - Category V Lighting Applications
- Table 2.1 from AS/NZS 1158.3.1 - Category P Lighting Applications for Road Reserves in Local Areas
- Table 2.2 from AS/NZS 1158.3.1 - Category P Lighting Applications for Pedestrian and Cyclist Paths
- Table 2.3 from AS/NZS 1158.3.1 - Category P Lighting Applications for Public Activity Areas (Excluding Car Parks)
- Table 2.4 from AS/NZS 1158.3.1 - Category P Lighting Applications for Connecting Elements
- Table 2.5 from AS/NZS 1158.3.1 - Category P Lighting Applications for Outdoor Car Parks (Including Rooftop Car Parks)

It is the responsibility of the designer to ensure they have current copies of AS/NZS 1158 and any other QLDC lighting standards, policies, and procedures.

8. LIGHTING CATEGORIES AND THE DISTRICT PLAN

To assist in the interpretation of this standard, QLDC has summarised AS/NZS 1158.3.1 Tables 3.3 - 3.7 of the standard to reflect the local needs based on the District Plan zones. Refer QLDC Table 1 below.

Category P (pedestrian) will be the main lighting standard used as it provides standards applicable to most of the roads managed by the council.

The designer should assess factors such as:

- Traffic flows – Using predicted / modelled flows at year 20 to inform the final Sub-Category selection.
- Composition of traffic (vehicular and/or pedestrian)
- The need to enhance amenity and the activities of adjacent businesses. Areas with high volumes of pedestrian movements associated with bars and restaurants will require different lighting consideration to business parks.
- Risk of crime
- The context of wider development within the area. This is especially important for Sub-divisions constructed in multiple stages. The traffic impact assessment should be referred to inform lighting sub-category selection by way of confirming traffic modelling over a 20-year period for the entire development and not just individual stage.

9. LIGHTING CATEGORIES P-CATEGORY

QLDC Table 1 Lighting Category Summary for Road Reserves in Local Areas (Category P)

Area of Activity	District Plan Zone	Lighting Subcategory*	Average Daily Traffic Flow
Local Roads or streets used primarily for access to abutting properties including residential properties	* Township, Residential Zones, Rural Zones, Special Zones	PR6	Less than 1,500 vehicles
	Town Centre, High Density Residential,	PR5	Greater than 1,500 but Less

	Industrial and Business zones		than 2,500 vehicles
Pathways (including cycle ways, footpaths along roads, walkways and park paths) where these have been identified for lighting.	Town Centres – designated safe routes and Cycle Commuter Connections	PP3 or PP4	N/A
	Town Centres - other pathways	PP3	N/A
	Pathways outside of Town Centres	PP5	N/A
Town Centre pedestrian activity areas (malls, open arcades, town squares, civic centres)	Town Centre	PA3	N/A
Townships – Main Street Business Area	Township	PR1 or PR2	N/A
Transport terminals and service areas with mixed pedestrian and vehicle movements during hours of darkness	All	PA3	N/A
Lit Pedestrian Underpass Rural Access Only	All	Refer Section 20.3 NZTA M30:2014 (Applies day and night)	N/A
Pedestrian Underpass Urban / Semi-Urban, forming part of a commuter route.	All	Refer Table 4 of BS 5489.1:2013 for Daytime Requirement (enclosed subway) PE1 for Night	N/A

10. LIGHTING CATEGORIES VEHICULAR TRAFFIC ROUTES

Although a number of high-volume vehicular routes within QLDC's geographical area belong to Waka Kotahi, there are still of high-volume roads that meet V-Category or higher P-Category criteria, and this will extend to key routes through new developments and subdivisions.

A site-specific assessment shall be undertaken by a lighting designer to confirm the appropriate lighting sub-category as per the requirements of Section 8 prior to undertaking any design. The following baseline guidance and ranges shall be considered for reference in attributing sub-categories for higher trafficked routes. Note that the use of V1 and V2 is not recommended for the QLDC region.

QLDC Table 2 Lighting Category Summary for Mostly Vehicular Traffic Routes (Category P and V)

Type of Road	Average Daily Traffic Flow	Lighting Subcategory*
Collector Road or Arterial within a district centre Urban Environment with high pedestrian movements, adjacent retail, bars/restaurants, regular intersections and on street parking.	Greater than 2,500 Vehicles	P-Category (PR1 or PR2)
Collector Road or Arterial within an Urban or Semi-Urban Environment. Outside of and connecting to a district Centre.	Greater than 2,500 but less than 5,000 Vehicles	P-Category (PR2, PR3 or PR5)
Collector Road or Arterial within an Urban or Semi-Urban Environment. Outside of and connecting to a district Centre.	Greater than 5,000 but less than 15,000 Vehicles	V4
Collector Road or Arterial within an Urban or Semi-Urban Environment. Outside of and connecting to a district Centre.	Greater than 15,000 Vehicles	V3
Collector Road or Arterial in Intrinsically Dark and Rural Areas	N/A	Unlit or Flag lighting

11. LIGHTING CATEGORIES CAR PARKS

The following criteria shall apply to lit car parking within the region. Limits to private car parks have also been included in the interest of reducing upward waste light on new commercial developments.

QLDC Table 3 Lighting Category Summary for Off Street Surface Car Parks (Category P)

Type of Car Park	Description of Use	Lighting Subcategory*	Car Park Capacity	Maximum Luminaire CCT
Town Centre Public Car Parks, Public Transport Hubs and High Use Private Car Parks	Town Centre (Inner CBD) locations, such as Queenstown, Wanaka and Frankton. Recommended Criteria for Larger Private Business Development, such as supermarkets and retail parks.	PC2	N/A for Public Greater than 30 Spaces for Private	3000k

District Centre or Semi-Urban Public Car Parks and Low Use Private Car Parks	Outside of inner CBD areas listed above and all other lit car parks within the region. Recommended Criteria for all private small business facilities.	PC3	N/A for Public Less than 30 Spaces for Private	3000k
--	---	-----	---	-------

12. DESIGN METHODOLOGY

The following definitions and sections describe the main types of road lighting calculations required and their application is dependent on the category of lighting required.

Table 4 Lighting design methodology

Calculation	Definition	Methodology	Category
Illuminance (E)	Illumination is a general expression for the process of light arriving at a surface and the physical measure of this is illuminance. Illuminance is the luminous flux (lumen - lm) arriving at a surface divided by the area of the illuminated surface.	Unit: lux (lx); 1 lx = 1 lm/m ² .	Illuminance calculations are required for category P roads and nominated locations on category V roads.
Luminance (L)	Luminance is the physical quantity of light corresponding to the brightness of a surface (e.g. a lamp, luminaire or reflecting material such as the road surface) when viewed from a specified direction.	Unit: candela per square metre (cd/m ²).	Luminance calculations are only required for category V roads.
Uniformity (U)	The uniformity is a calculated ratio that is used to measure how evenly the light is distributed over a given area or length of roadway.	Uniformity calculations are required for both category V and P roads; however, the method of calculation differs between the two categories.	

CATEGORY V DESIGN OBJECTIVES

The principal design objectives for category V lighting are to provide the following:

- (a) Luminance and uniformity of luminance of the carriageway surface to a specified level.
- (b) Glare control to a specified level.

- (c) Illumination on intersections, carriageway verges, splitter islands and other nominated locations to a specified level.
- (d) Limitation of upward spill light from luminaires to a specified level.
- (e) A maintenance regime such that the lighting scheme complies at all times during each maintenance cycle.
- (f) Minimal energy consumption.
- (g) Minimal whole of life cost and Warranty opportunities.

Refer to AS/NZS 1158.2 for the minimum design areas and applicable calculation fields.

CATEGORY P DESIGN OBJECTIVES

The principal design objectives for category P lighting are to provide the following:

- (a) Illuminance and uniformity of illuminance over the road reserve to a specified level.
- (b) Glare control to a specified level.
- (c) Limitation of upward spill light from luminaires to a specified level.
- (d) Limitation to a specified level of the light spilled into adjacent properties.
- (e) A maintenance regime such that the lighting scheme complies at all times during each maintenance cycle.
- (f) Minimal energy consumption.
- (g) Minimal whole of life cost and Warranty opportunities.

Refer to AS/NZS 1158.2 for the minimum design areas and applicable calculation fields.

LIGHT TECHNICAL PARAMETERS

The principal design objectives (outlined in the above two sections) are formally specified in terms of the following light technical parameters (LTPs):

- (a) Parameters that relate to the attainment of the required level of lighting performance.
- (b) Parameters that limit the adverse effects of the lighting on:
 - i. Users of the lit space e.g., pedestrians, vehicle drivers (i.e., control of glare);
 - ii. Night sky viewing conditions (i.e., reducing sky glow);
 - iii. Occupants of adjoining properties (i.e., minimise the amount of spill light).

Reference should be made to the relevant parts of the current AS/NZS 1158 series that provide the minimum levels of compliance that are required for each category and subcategory of lighting. Relevant parts include:

- Table 2.2 from AS/NZS 1158.1.1 - Values of LTPs for Category V Lighting
- Table 3.3 from AS/NZS 1158.3.1 - Values of LTPs for Category P Lighting of Roads in Local Areas
- Table 3.4 from AS/NZS 1158.3.1 - Values of LTPs for Category P Lighting of Pathways and Cyclist Paths
- Table 3.5 from AS/NZS 1158.3.1 - Values of LTPs for Category P Lighting of Public Activity Areas (Excluding Car Parks)
- Table 3.6 from AS/NZS 1158.3.1 - Values of LTPs for Category P Lighting of Connecting Elements

- Table 3.7 from AS/NZS 1158.3.1 - Values of LTPs for Category P Lighting of Outdoor Car Parks (Including Rooftop Car Parks)

It is the responsibility of the designer to ensure they have current copies of AS/NZS 1158 and any other QLDC lighting standards, policies and procedures.

CALCULATION OF LIGHT TECHNICAL PARAMETERS

The calculations of all Light Technical Parameters (LTPs) for category V and P roads shall be carried out in accordance with the computer-based design procedures provided within AS/NZS 1158.2. This standard provides the basic formulae for the LTPs and the associated grid of points (calculation field) over which the calculations are to be made. Hand calculations shall not be accepted.

The use of a specific software application called "SAA STAN" is mandatory for the calculation of the luminance based LTPs for the category V straight road elements. This can be achieved using the software such as "Perfect Lite" or another shell program that is built around "SAA STAN" and which can be demonstrated to reproduce the values of all LTPs provided by "Perfect Lite".

"AGi32" shall be used for the illuminance-based calculations required for category V road lighting designs.

"AGi32" shall be used for the illuminance-based calculations required for category P road lighting designs.

Other software packages confirming compliance with the AS/NZS 1158 calculation procedure may be utilised if appropriately demonstrated by the designer and agreed prior to design by QLDC.

It shall be the responsibility of the designer to ensure the appropriate software is used to carry out all the required calculations.

Spill light calculations shall be undertaken for all streetlights adjoining residential activities. Horizontal measured at the boundary by a line of points at ground level at 2m intervals and vertical measured at the boundary with the meter facing parallel to the boundary towards the light source by a line of points at 2m spacing from 0m to a height of 12m.

MAINTENANCE FACTOR

A design maintenance factor (MF) is used in the calculations to account for the combined light losses resulting from depreciation in the LED's lumen output and accumulation of dirt on the luminaire over a nominated maintenance period.

The MF is calculated as the product of the following depreciation factors:

- (a) *Luminaire Maintenance Factor (LMF)*: QLDC have adopted the guidance in IES Technical Report RES-1-16 with the intended luminaire cleaning regime for LED Street Lighting being an 8-year cycle for all approved IP6X fittings, as such an LMF of 0.92 for a luminaire with a visor or 0.78 for a luminaire with exposed optics shall be used.
- (b) *Light Source Lumen Depreciation Factor (LLD)*: The amount of light (lumen output) available at the end of a nominated operating period (85,000 hours - 20 years), as a proportion of the initial lumen output (when the LED was new), expressed as a decimal fraction. The LLD takes into account the operating temperature, driver current and electrical properties and shall be obtained from the luminaire supplier.

(c)

The design MF can be calculated as follows:

$$MF = LMF \times LLD$$

As part of the design delivery process the designer is required to provide information on the MF used in the calculations including the calculation for the luminaires specified and luminaire data to support the selections.

The maximum design MF shall not exceed 0.8 even if the MF calculation yields a higher result.

DESIGN OUTPUT DELIVERABLES

The designer shall submit the following design documents for QLDC approval before commencement of the installation works. Refer to Appendix D of AS/NZS 1158.1.1 and Appendix C of AS/NZS 1158.3.1 for a full list of the mandatory design information required to be submitted. Onus is on the designer to prove the design meets the relevant codes and consents. Work shall not be started until the design documents have been approved by QLDC.

QLDC may request that any submitted design is peer reviewed by one of our approved Lighting Design Reviewers at the cost of the applicant.

Design Submission check sheet

The QLDC design checklist can be found on the QLDC website. Note any decorative/heritage columns or luminaires must be approved by Property & Infrastructure via the design checksheet sign off. Specific requirements are as follows.

Layout Drawings

The layout drawings shall be produced using a CAD based computer program, examples can be found in the Appendix and shall include the following minimum information:

The drawings shall show:

- (a) Locations of all poles (dedicated lighting poles and/or overhead power poles) where the luminaires are installed and dimensions clearly showing the pole spacings.
- (b) A dedicated Lighting Column setback for each position shall be provided showing the distance from the kerb or boundary line. A general note will not be accepted.
- (c) All the roadway features including kerbs, carriageway edges, lane markings, property boundaries, traffic/splitter islands, pedestrian crossings, and any other features that form part of the road reserve or carriageway.
- (d) Equipment legend detailing the luminaire types (LED count and driver current/size, power rating), luminaire mounting arrangements (tilt angles, heights, outreaches, etc., poles and outreach arms and any specific column installation details (ground planted, slip base, etc.).
- (e) Interaction with above ground and below ground services - annotating minimum clearances required as well as applicable codes to determine those clearance.
- (f) Any applicable calculation areas.
- (g) The Lighting design drawings shall show the location of all overhead powerline assets and the associated horizontal ECP34 clearances for structure without engineering assessment.

Design Report or Design Statement

A design report or design statement shall be provided along with layout drawings and shall contain comprehensive information detailing all aspects of the design and (in conjunction with the layout drawings) shall be used as a method of verification that the design is fully compliant with the New Zealand requirements of AS/NZS 1158 and any other QLDC requirements. As a minimum the following information shall be provided:

- (a) The applicable categories and subcategories for each road.
- (b) A list of the design methods employed and presentation of the modelling results to demonstrate compliance. This can be a list of tabulated calculation results with suitable printouts from the lighting software used.
- (c) Any areas of non-compliance (with the NZ standards and/or QLDC requirements) shall be noted along with explanatory notes describing why a fully complying design was not achieved. QLDC approval shall be required for any areas of non-compliance.
- (d) Details of the lighting arrangement (single sided, staggered, opposite, etc.) and geometry (spacing, mounting height, overhang, up cast angle).
- (e) Details of the lighting columns including type, size, material, finish and any particular mounting requirements (frangible, shear based, etc.).
- (f) Luminaire details including luminaire name, description, input power, LED count, driver current, optical setting, lumen output and IP/IK rating.
- (g) The origin of the photometric file (used in the design modelling) for the luminaires.
- (h) The name and source of the computer software used.
- (i) The MF used and the basis for the MF selection (refer to section 3.3.5).
- (j) Design report should make comment on key service crossing/s interactions, detailing those minimum separations and clearances have been maintained, and/or where technical deviations have been required and contain/reference consents from the respective utility provider for these.
- (k)** State who signed off along with relevant credentials/training/experience, refer Section 22.2 of NZTA M30:2014 for acceptable experience.

Calculation Results (Refer to example in Appendix)

- A printout of the calculation results (directly from the lighting software) shall be required to be submitted for approval along with the other design information listed above. The calculation results must be printed directly from the lighting software (e.g. AGi32).
- QLDC will not accept tabulated results (on drawings) in lieu of the actual software printouts.
- Software files of the final accepted design (and any subsequent revisions) should be submitted to QLDC.

Obtrusive Light Calculation Results

Obtrusive light calculations shall be carried out in accordance with AS/NZS 4282 for all new category V street lighting installations, outdoor sports fields and industrial/commercial outdoor work areas adjoining residential properties. All obtrusive light calculations shall be carried out with a maintenance factor of 1.0. Spill light calculations are not required for category P lighting installations unless specifically requested by QLDC. Examples where spill light calculations may be required include (but are not limited to):

- All car parks bordering residential areas

- Lighting of pedestrian activity areas or narrow alleyways adjacent to residential (particularly multi-story apartments where windows may be close to light poles)
- Lighting of areas elevated above other residential developments

Note that the control of glare and upward waste light will need to be demonstrated for all new Category P lighting schemes in accordance with AS/NZS 1158.3.1

QLDC will reject any design that is submitted with missing or incomplete information, or any unjustified areas of non-compliance.

13. LOCAL AREA TRAFFIC MANAGEMENT (LATM) DEVICES

LATM devices on:

- a. V-Category Roads shall be lit to the requirements of AS/NZS 1158.3.1:2020 Section 4.5.2 for the application for the design area. With the point horizontal minimum illuminance requirement being that as defined in Table 2.2 of AS/NZS 1158.1.1:2005 for the selected Sub-Category.
- b. P-Category non-local roads shall be lit to the requirements of AS/NZS 1158.3.1:2020 Section 4.5.2.
- c. Sub-Category PR5 and PR6 local roads within residential sub-divisions shall be lit (and treated) to the requirements of AS/NZS 1158.3.1:2020 Section 4.5.3. However, the maximum '0.25S' stated in sub-clause (b) is replaced with '5 metres'. The intention of this requirement is to reduce the over lighting of low trafficked residential roads mostly accessed by local residents with no through traffic.

14. BUS STOPS

A lighting column shall be located on the same side of the road as the bus stop, within 10m of the embarkation point.

When a bus turns into or out of a bus stop the bus may overhang the kerb. To minimise the risk of bus vs column collision, any lighting column must be setback at least 3m from the face of kerb where no bus shelter is present, or in line with the shelter structure where a shelter is provided.

Lighting columns shall not be located within 2m of a bus shelter to limit potential public roof top access.

15. FLAG LIGHTING

At isolated rural unlit intersections, consideration of night-time safety issues should occur, the designer should provide details as to whether flag lighting has been considered and reasoning for the outcome. Flag lighting (in addition to reflective strips) should be used as a means of providing advance warning to alert approaching motorists to the presence of the intersection. In such cases specific illuminance design is not required and the following table has been provided as a guide to selecting the most appropriate luminaire and mounting parameters.

The designer should also follow any NZTA guidelines around the use of flag lighting at isolated rural unlit intersections.

QLDC Table 5 Parameters for Flag Lighting

Vehicle Volume (VPD)	Subcategory	Recommended Mounting Height (m)	Recommended Lumen Output (lm)
>15,000	V3	10 or 12	12,500
< 15,000	V4	8 or 10	7,500

16. INNOVATION AND LIGHTING TRIALS

The intention of this document is to inform a standardised approach to exterior lighting within the region. However, it is accepted that standards and technical specifications do not keep up with industry developments. QLDC would therefore consider any monitored ‘trial’ design proposal that utilises technology or practices not covered by the document that are focussed toward the reduction of lighting pollution in the interest of preserving the dark sky amenity of the region. The current topics of interest are listed as follows:

- Use of Amber LED Luminaires.
- Use of lower Correlated Colour Temperature White Light Luminaires.
- Part night Street Lighting Switch off in Rural Townships
- Dimming and presence detection to activate Street Lighting during low trafficked hours of operation.

Additional requirements such as community and stakeholder engagement may be required to facilitate some of the ‘areas of interest’ listed above. It is expected that any proposal submitted for review will identify all project requirements and have undertaken appropriate preliminary risk assessments in the respect of Traffic safety and potential changes in criminal behaviours associated with the proposed lighting trial. QLDC also requires that a cost benefit analysis is undertaken to ensure that no trial implemented under this clause has adverse effects on capital, maintenance or energy budgets.

17. TEMPORARY CONSTRUCTION LIGHTING

Where a roadway, public space or public right of way is currently illuminated by public lighting (or Street Lighting), it is required that the system be maintained to ensure public safety during the hours of darkness.

Where construction takes place within the aforementioned areas, changes to a public lighting installation may be required to facilitate those changes or for the purposes of asset renewal. In such instances, it is the mandatory requirement of QLDC that the Constructor maintains the existing street lighting system within their site, until a point in time where the new lighting is confirmed fully operable.

Temporary Lighting is to ensure the continued safe movement of all road users, however, there is a focus on pedestrians, cyclists and construction workers around the ‘site’, who are deemed to be at higher risk of incident.

1.17.I MINIMUM REQUIREMENTS

The levels of illumination on the road and/or public space prior to the full (or partial) demolition of the existing street lighting system shall be maintained throughout the hours of darkness until the new lighting system is in full operation.

It is anticipated that in most instances the Constructor will be able to achieve the temporary lighting minimum requirements by establishing new permanent street lighting prior to the removal of the existing assets.

Where permanent lighting systems cannot be maintained throughout construction activities for practical reasons, or no existing lighting is present on site and temporary lighting is required during construction, the Constructor must satisfy additional requirements. The main Constructor must seek advice directly from QLDC to confirm which measures are appropriate prior to physical works beginning.

1.17.II ADDITIONAL REQUIREMENTS

Where comprehensive changes are being made to the infrastructure, a risk-based analysis must be undertaken, and temporary lighting assets may be required during the various stages of construction to replace permanent lighting assets that must be removed for practical reasons. A temporary lighting proposal may take into account the use of Temporary Traffic Management in establishing a practical solution for the site.

It is the preference of QLDC that standard lighting columns with appropriately sized luminaires on moveable concrete foundations are provided. These shall be isolated from public access and shall be arranged to provide adequate illumination as per the minimum requirements. The Constructor will be required to engage a suitably qualified lighting designer (as nominated by QLDC) to confirm the layout required and assess any changes resulting from the construction staging.

Any proposed temporary layout shall be submitted to QLDC for approval prior to implementation and the Constructor must arrange for temporary supplies in liaison with Aurora or have an adequate solar arrangement to operate all night.

Where new roading features are created which require higher lighting levels than the previous usage of the space, these devices shall either remain isolated until permanent lighting is operational, or temporary lighting shall be provided to the requirements of the AS/NZS 1158 and the current version of this document.

1.17.III PEDESTRIAN WALKWAYS

Where pedestrians are affected by temporary works which create enclosed separation from the roading corridor by way of solid barriers greater than 1.5 m height, a 'shipping container' style walk through or under scaffold. The Constructor must provide illumination to a minimum of a 20lux average and 4 lux point horizontal illuminance, utilising white light. This is preferably achieved with 'batten style' linear fittings surface mounted to the underside of the walkthrough's ceiling or fixed to the side of the separating barrier system.

1.17.IV EXCLUSIONS

Proprietary generator-based lighting rigs to illuminate public spaces for the purposes outlined in this section shall not be permitted due to glare and noise issues.

18. DIFFERENCES BETWEEN THE QLDC TECHNICAL SPECIFICATION AND AS/NZS STANDARDS

Where there are differences between the QLDC Technical Specification and the AS/NZS Standards this Technical Specification takes precedence. The following are instances where QLDC's requirements differ from (or are in addition to) the Standards:

- Luminaire tilt angles shall not exceed 0° for Category P roads and 5° for Category V roads unless otherwise approved by QLDC.
- Obtrusive light shall be controlled as per District Plan
- On Category V roads the Threshold Increment (TI) shall not exceed 12% (AS/NZS 1158 allows up to 20%)
- AS/NZS 1158.3.1:2020 Section 4.5.3 (b) '0.25S' is replaced with '5 metres'.
- Increased daytime lighting requirement for Pedestrian Underpasses, referring to BS 5489.1:2013 table 4.

The QLDC may also impose other requirements (that deviate from these specifications and/or the AS/NZS Standards) based on special site or community specific requirements, and in such cases the applicant shall be advised accordingly.

19. EQUIPMENT SELECTION AND INSTALLATION REQUIREMENTS

All equipment specified by the designer shall be subject to final approval by QLDC. The design life and durability performance shall be 20 years for all luminaires and 50 years for all other equipment.

QLDC are seeking to reduce the number of different equipment within the district with a view to improving the maintenance and renewal efficiency.

Any new design shall adhere to the approved equipment process. Where decorative equipment has been used in existing development, QLDC's preference will be to discontinue their use in future stages of the development, to reduce future district wide variance in equipment.

The use of different Street Light families within a design to address localised design criteria, such as the increased illuminance requirements for LATM devices, is prohibited. A consistency of assets on the network is preferred.

20. LUMINAIRES

The following LED minimum performance requirements are applicable to all new lighting installations and shall be read in conjunction with NZTA M30:

QLDC Table 6 LED Minimum Performance Requirements

LED Minimum Performance Requirements	
Main Characteristics	
Colour Temperature	Not more than 3000K
CRI	≥ 70
Rated Optical Life	≥ 85,000 hours
Insulation Class	II

All

LED Minimum Performance Requirements	
Protection Degree	IP66
Impact Protection	IK08
LED Modules	Removable
Luminaire Tilt Angle (when installed)	0° - 5° above the horizontal (Adjustable on site).
Weight	≤ 15kg
Mounting	Bracket attachment Ø42mm to Ø60mm
Temperature Range	-10° to +40°
Gear Tray	Removable plate
DALI	Dimmable driver
NEMA socket	7-Pin
Electrical Characteristics	
Rated Voltage	230V (50Hz)
Power Factor	>0.9 (at full load)
Integrated Surge Protection	Up 10kV/10kA
Total Harmonic Distortion	≤ 20%

luminaires shall be designed to enable the LED light engine to be replaced and/or upgraded. The IP66 rating of the complete luminaire shall not be compromised as a result of either replacement or upgrade of the luminaire components.

The integral Surge Protection Device (SPD) shall be an electronic device capable of sustaining 5 strikes with automatic reset capability and must be of a type capable of protecting all electronic components within the luminaire. Varistor type SPD devices shall not be used as their operating times are not always fast enough to protect electronic components. Suppliers shall provide details of the SPD's characteristics and demonstrate that the installed device will protect all electronic componentry.

The 20-year design life applies to all component parts of the luminaire and includes the housing, lens, gaskets, LEDs, compartments, drivers, and control gear.

In addition to meeting the above minimum standards the LED manufacturer and/or supplier shall provide a 10-year performance warranty on the luminaire, based on normal LED operation within the QLDC district. The warranty must be in the name of QLDC, and details must be provided with As-built information.

The introduction of smart computerised central management systems (CMS) can provide greater flexibility in how lighting systems are operated. Simple on/off functionality can now be replaced with a CMS which allows remote control and dimming functions to be implemented. QLDC requires each

LED luminaire to be provided with a DALI dimmable driver and a 7-Pin NEMA socket (complying with ANSI C136.41) complete with Zodian SS6 20:20 photocell QLDC will advise each applicant of any other CMS requirements.

Refer to NZTA M30 Specification and Guidelines for Road Lighting Design for the acceptable LED testing procedures and methods of determining optical performance, production of photometric files (IES and CIE format) and method of measuring lumen depreciation.

NZTA M30 contains a list of accepted LED luminaires that have been assessed as meeting the M30 criteria.

QLDC are seeking to reduce the number of different luminaires and columns within the district with a view to improving the maintenance and renewal efficiency. QLDC have an approved luminaire list which can be found in Appendix . Refer to section 3.1.

QLDC varies from NZTA M30: where it is deemed more appropriate to apply a lower colour temperature. Specifically, 3000K is the colour temperature required for exterior lighting. Note that there may be some instances where a higher colour temperature (above 3000K) is justified subject to QLDC approval and these areas may include:

- Major transport hubs or outdoor areas where high-definition CCTV coverage is required
- Outdoor sports fields
- Outdoor work areas e.g., truck depots, materials handling facilities, freight hubs, public works infrastructure and facilities etc

21. LIGHTING COLUMNS

The new luminaires shall be mounted on any combination of the following configurations:

- (a) New street lighting columns.
- (b) Existing overhead power poles using suitable outreach arms mounted onto each power pole.
- (c) Joint use mast arm (JUMA) or joint use signal (JUSP) lighting columns.
- (d) Mounted directly onto buildings (or other infrastructure) using suitable mounting brackets and hardware.

All new lighting columns (and mounting hardware) shall comply with the relevant structural standards and the performance and durability requirements of NZTA M26 in addition to any local environmental conditions such as high wind and/or snow loadings and poor ground conditions.

In the case of any building mounted luminaires, permission from the building (or asset) owner is required prior to installation.

NEW LIGHTING COLUMNS

Unless otherwise advised by QLDC all new lighting columns shall be octagonal steel (hot dip galvanised) ground planted poles complete with curved outreach arms.

The column shall be unpainted unless there are visual or environmental concerns that need to be addressed. QLDC shall approve the column via the QLDC Design checksheet found on the QLDC website, any deviations during implementation shall need to be resubmitted for approval. If painted, painting shall be carried out by the column manufacturer during fabrication and assembly.

All new octagonal lighting column shall be of the frangible type as a minimum requirement, however certain ground conditions or safety issues may require the columns are flange based (with either a stub base or concrete foundation). High speed areas exceeding 70kph may require use of shear-based columns where appropriate safe setbacks cannot be achieved. Specific design may also be required at locations that have particular environmental or physical constraints i.e., Bridges, retaining walls, gabion baskets, or other structural elements that may be present.

Decorative or heritage lighting columns and luminaires may be permitted on some P category residential streets, minor roads and in some intermediate roads as part of a new subdivision, or in amenity areas provided they meet all the performance requirements listed within this design guide and be on the QLDC approved list. It should be noted that decorative columns are not expected to meet the frangible criteria and therefore their use must be restricted to low speed (<50kph) environments and columns must be appropriately setback from the kerb (preferably back on the boundary). These must be approved by QLDC via the QLDC design checklist.

Lighting columns shall be positioned so that the gear doors are safely accessible to a maintenance operative or either handedness. Columns placed behind physical structures such as safety barriers or bridge railings will require special consideration to ensure that access to the gear compartment is not blocked and that the door is orientated correctly. This may lead to the bespoke requirement for a custom height door on bridge mounted columns for example, so that the gear compartment is accessible from the bridge deck without the need for an elevated work platform.

Column Numbers

All Columns must be fitted with a unique QLDC pole number. The pole numbers become a key reference for each asset and the location and details of these numbers must align to the asset data provided to Council as part of the 224c Application or any capitalworks.

The column numbers should meet the following specification.

S1343, Rotag Diamond Engraved anodised marine grade aluminium QLDC streetlight number; 175x25mm each.

Column numbers can be obtained by contacting QLDC and should be installed between 1.8-2 meters high from ground level.



Luminaire Mounting Parameters

New lighting columns shall be designed and constructed based on the luminaire mounting parameters, weights and sail areas specified in the following table.

Table 7 Luminaire Mounting Parameters

Luminaire Mounting Height (m)	Maximum Bracket Outreach (m)	Maximum Luminaire Weight (kg)	Maximum Luminaire Sail Area (m ²)
12.00	4	15	0.15
10.50	4	15	0.15
9.00	3	10	0.12
7.50	3	9	0.10
6.00	2	9	0.10

Where possible the above standard mounting heights shall be used, however there may be special circumstances where other mounting heights and/or outreach lengths are required, and in such cases compliance with the structural and durability requirements of NZTA M26 will need to be demonstrated in addition to obtaining QLDC approval prior to column selection.

Refer to Appendix for typical arrangement.

Bollards are not considered to provide adequate street lighting and will only be acceptable for amenity (Parks and Reserves) lighting, or for private lighting schemes that are not to be vested in Council. Bollards must meet the requirements for shielding of upward light. Approval for use of bollards from Property & Infrastructure Engineering Team from QLDC must be obtained at Engineering Acceptance.

Existing Power Poles

At locations where there are existing overhead power poles and it is not practical to install new street lighting poles, the luminaires may be able to be mounted onto the existing poles using suitable steel (hot dip galvanised) outreach arms, subject to approval from the local electricity distribution company.

All new outreach arms (and mounting hardware) shall comply with the relevant structural standards and the steel performance and durability requirements of NZTA M26.

Traffic Poles

Where new lighting is required at signalised intersections involving the addition of new signal poles the preference is to mount the luminaires onto Joint Use Signal Poles (JUSP) or Joint Use Mast Arm (JUMA) or poles.

22. POWER SUPPLY AND CONTROL REQUIREMENTS

Power Supply and Electrical Requirements

The design and installation of power supplies to the new lighting, including alterations and extensions to the street lighting network (SLN), shall be undertaken by an experienced and competent designer and/or contractor "approved" by the local electricity network company.

All work (including design and construction) shall comply with the Electricity Act 1992, the Electricity (Safety) Regulations 2010, the NZ Wiring Rules (AS/NZS 3000) and (as applicable) any electricity network company rules and procedures.

Works

Any work (including design and construction) associated with extending, modifying or establishing the SLN infrastructure shall be carried out by an experienced and competent contractor “approved” by the local electricity network company. The work shall be carried out in accordance with the requirements of the local electricity network company and any other relevant electrical regulations and standards including the Electricity Act 1992, the Electricity (Safety) Regulations 2010 and NZECP 35.

Electrical Installation unmetered street lighting

For Street Lighting assets within the legal road reserve, the following applies.

All installation work associated with the internal wiring (excluding the SLN cabling works) shall be undertaken by a competent person in accordance with the Electricity Act 1992, the Electricity (Safety) Regulations 2010 and the NZ Wiring Rules (AS/NZS 3000). The installation works shall include:

- Supply and installation of fuse panel board (made from non-conducting material such as Formica or similar electromechanical grade laminate) within the fuse panel cavity at the column base.
- Supply and installation of front wired 32A rated fuse holder (complete with 10A HRC fuse link) onto fuse panel.
- Supply and installation of earthing equipment including neutral and earth studs, neutral-earth link, earth electrode (driven earth rod) and all earthing conductors. Note that the connection onto the earth electrode shall be accessible for inspection either from within the column fuse panel or access pit adjacent the column.
- Supply and installation of luminaire and internal cable from the fuse panel to the luminaire. The internal cabling installation includes the earth and neutral conductors from earth/neutral studs and phase conductor from top (or exit) side of the main fuse holder and connection onto the luminaire terminals.

Refer to Diagram 1 for further details.

Note that Diagram 1 provides typical details only and alternative equipment may be installed (e.g., miniature circuit breaker rather than fuse holder) provided the complete electrical installation complies with the Electricity Act 1992, the Electricity (Safety) Regulations 2010 and the NZ Wiring Rules (AS/NZS 3000).

Electrical Installation – other

The application of this section applies in the following circumstances:

1. Public Street Lighting assets outside of the legal road reserve (e.g., Council Owned Parks and Footpaths), or a freehold situation, where an easement may be required for the electrical cabling.
2. QLDC owned Feature or Amenity Lighting assets.

Both installation types are to be serviced via a QLDC owned reticulation network and electrical cabinet with a metered utility supply. The designer shall be responsible for designing the electrical reticulation and associated control to the requirements of AS/NZS 3000.

The following minimum requirements (applying Sections 22 (a) and (b)) for the design of this new infrastructure shall be expected:

- a. The designer shall ascertain the existing supply characteristics and details (transformer, etc.).
- b. The designer shall ascertain any existing cabling networks' details (cable sizes, cable lengths, etc.) by checking the As-Built Documentation (drawings, schedules, etc.);
- c. The above information shall be used by the designer for the calculations of the Voltage Drop, Earth Fault Loop Impedance and Fault Levels at the various new luminaire's locations – to prove compliance with the Mandatory Testing requirements of AS/NZS 3000:2007, Section 8.
- d. The designer shall check for and ensure that sufficient space can be utilised within the QLDC owned electrical cabinets – for the installation of the new meter c/w Current Transformers (where required) and that the point of Isolation for the new lighting circuits supply is agreed with QLDC.
- e. The designer shall check and co-ordinate the new protection devices of the new lighting circuits with the protection (MCB, Fuse, etc.) placed on the QLDC owned cable – to prove discrimination.
- f. For these design requirements the following shall be documented and submitted for approval:
 - Drawings and the detailing of the proposed lighting
 - New conduits / ducts routes c/w sizes shown on the drawings.
 - New or revisions to existing Lighting Controls schematic diagrams to be provided.
 - Schedules / drawings detailing new circuits' protection, cable sizes, controls, etc.
 - Specification details – proving compliance with AS/NZS standards.

a) Public lighting assets outside of the legal road reserve

Typically, these lighting installations (columns and streetlights) fall within QLDC parks, rights of way and recreational spaces where they are considered public lighting assets but are unsuitable for conventional utility unmetered street lighting arrangements due to being outside of the legal roading designation.

The Designer shall design a cable configuration along the pathway or area to fit the number and location of supply points. The design should have an objective of providing a cost-effective outcome with the least number of supply points along the route.

At each supply point establish a switchboard cabinet with a meter.

The number of lights connected to a single circuit shall be limited to ensure that the load is no more than 50% of the circuit protection rating and with no greater than 2.5% voltage drop from the point of connection to the network, at the furthest luminaire.

Preferably, run a three phase 4core 10mm² (minimum) Cu NS PVC/XLPE, with luminaires connected in alternating sequence to phase A, B or C.

b) Feature and amenity lighting assets

Where feature or amenity lighting is to be used, this typically requires luminaires of a non-standard street lighting type with varying size and application. For example, inground, bollard and under seat strip lights. Whether these assets are in a road reserve or non-road reserve area, they are unsuitable for utility un-metred street lighting supply arrangements. Therefore, a bespoke electrical reticulation installation (which shall be metered as described above) is required which the designer shall undertake to the requirements of AS/NZS 3000. Asbuilt details must be supplied indicating cable location.

In the case of 230V luminaires, use round 2core+ECC 2.5mm² (minimum) Cu PVC/PVC cable in conduit in accordance with AS/NZS 3000. IP68 joint and tail down as required at each light (to suit the available

cable entry and termination space for the luminaire). 230V rated supplies shall not be installed within benches, seating platforms, handrails, etc.

In the case of extra low voltage (ELV) luminaires, run 2core 1.5mm² (minimum) Cu PVC/PVC cable in conduit. Remote drivers will be located in a suitable IP rated cabinet location, preferably at the point of supply and easily accessible.

c) Electrical installation – small connected non-street lighting loads

Where small quantities of lighting assets are required for the purposes of feature lighting or to illuminate short lengths of parkland footpaths, such as bollards in a sub-division – the dedicated supply points and associated meters required by the criteria above is not desirable, as this could lead to a proliferation of electrical meters on the network.

To offer flexibility, where small electrical loads (less than 100W) and less than 4 luminaires are required, a designed QLDC owned 'sub service' can be utilised from the nearest adjacent Street Lighting Asset. This approach **must** be agreed with QLDC prior to design taking place and approval will be given on a case-by-case basis. This approach is only acceptable for localised use within a project to address a limited number of lights, it would not be permitted across multiple clusters on the same Road or Development project. In that instance, the dedicated supply criteria above would apply.

The Street Lighting Asset feeding this arrangement will be required to have sufficient space within the gear area to house the additional fusing and control arrangement, normally a 'double door' column will be needed. The design of the electrical fuse board arrangement and control to accommodate the subservice will require detailing in the design submission and shall satisfy the requirements of AS/NZS 3000.

The preference is for this arrangement to be utilised in conjunction with 230V luminaires (integral gear) with a round 2core+ECC 2.5mm² (minimum) Cu PVC/PVC cable in conduit.

For Extra Low Voltage luminaires, the issue of restricted space associated with housing remote drivers within the adjacent lighting column may prove difficult to resolve and thus this is not preferred. However, the minimum cable size shall be round 2core 1.5mm² (minimum) Cu PVC/PVC cable in conduit.

For these design requirements the following reduced requirements shall be documented and submitted for approval:

- Drawings and the detailing of the proposed lighting
- New circuiting details provided on the drawings.
- New conduits / ducts routes c/w sizes shown on the drawings.
- Schedules / drawings detailing new circuits' protection, cable sizes, controls, etc.
- Specification details – proving compliance with AS/NZS standards.

23. STREET LIGHTING CONTROL SYSTEMS

Road lighting control systems typically involve any combination of the following:

- (a) Manual switching from a central location (area substation) supplying a group of luminaires.
- (b) Photocell control from a central location supplying a group of luminaires or individual photocells mounted on each luminaire.
- (c) Central Management System (CMS) or Supervisory, Control and Data Acquisition (SCADA) control using signals transmitted over a local network to remotely control and/or dim groups of lights.

As a minimum all new luminaires shall come with dimmable drivers in accordance with M30, refer to section 20.

24. COMMUNITY SPECIFIC DESIGN GUIDELINES

This section draws attention to urban design, the QLDC District Plan, community specific requirements as well non roading related elements. It is important to adhere to the Southern Light Part One - A Lighting Strategy, the operative QLDC District Plan and the QLDC Urban Design Strategy which provides design guidelines and other urban design reference documents.

Where community specific guidelines are available these shall be taken into consideration throughout the design and construction of subdivisions and development. Contact should be made to QLDC to ascertain current status of community specific plans.

25. DESIGN GUIDELINES FOR LIGHTING NOT COVERED IN AS/NZS 1158

AS/NZS 1158 provides minimum performance and design requirements for the lighting of roads and public spaces. However, there are other forms of outdoor lighting that are not covered within the AS/NZS 1158 series (or are included in other standards), and the following sections provide guidance to designers and others responsible for lighting schemes (permanent or temporary) that fall outside AS/NZS 1158.

As a minimum requirement all lighting listed within this section shall comply with the requirements of AS/NZS 4282 which covers the control of the obtrusive effects of the following outdoor lighting applications:

- For work or recreation (outdoor workplace lighting shall also comply with AS/NZS 1680.5)
- For safety or security
- For amenity
- For advertising or display

Vested infrastructure must be cost effective and should be a nationally and readily available product, approved by QLDC.

26. FEATURE LIGHTING (UP-LIGHTING AND FLOOD LIGHTING)

Adherence to the Southern Light Strategy and Technical Specifications gives the Council and private owners the opportunity to celebrate and highlight the special features in our community without over saturation of lighting. While some festive and feature lighting may contravene the upward waste light requirement, there are some circumstances where this will be allowed through both permanent and temporary installations. Special dispensation must be approved by QLDC, and consideration may reflect the communities' intention to seek accreditation for Dark Skies.

Feature lighting (including in-ground up-lighting, projectors, and above ground floodlighting) shall only be provided for specific locations that are of special or historical significance. There are no specific minimum or maximum illumination levels, however each individual design shall be submitted (for approval by Council) with accompanying calculations clearly showing the horizontal and/or vertical illuminance values corresponding to each feature being lit. Any design submitted shall identify the ambient light of the general area and calculated ratio of the illuminated feature against the background lighting. Recommended Ratios:

- 2:1 – To be visible.
- 5:1 – To 'Stand out'

In the case of a statue, tree, building façade or sign the vertical design area shall match (as closely as possible) the item being illuminated. Where multiple floodlights are required to illuminate the perimeter of a tree or statue a vertical calculation shall be required for each floodlight aimed at the item.

Any lighting installation, either temporary or permanent, that is installed within a QLDC tree or within the root zone of a QLDC tree shall be required to be assessed regarding any potential harmful or negative effect the installation may have on the wellbeing of the subject tree. This assessment shall be undertaken by the QLDC Arborist, and should it be considered that the installation will likely have a detrimental effect on the wellbeing of the subject tree, approval shall not be granted.

Should approval be granted, it will likely be subject to conditions to ensure that there is no subsequent detrimental effect on the subject tree, such conditions may include:

- The installation and removal of any decorative lighting within the crown of a QLDC tree shall be installed by a suitably qualified professional arborist
- Any works within the root zone of a QLDC tree (cable installation etc) shall be overseen and monitored by a suitably qualified professional arborist
- Only low wattage LED shall be installed in trees. Conventional incandescent light bulbs create excessive heat that can be harmful to the tree

All floodlights shall be directionally aimed and focused towards the items required to be illuminated, and in no case shall any up-light be aimed straight up into the atmosphere. The Council's preference is to have building or pole mounted floodlights aimed down (below the horizontal) towards the items being lit. The Council recognises that this may not always be practical and will allow in-ground floodlights to be used subject to their approval.

The Council reserves the right to withhold approval for any feature lighting in a public setting if the adverse lighting effects are deemed to be too excessive, and in such cases the lighting designer may be required to submit an alternative design using lower lumen output fittings.

All feature lighting equipment (luminaires, housings, columns, fixing brackets, etc) shall comply with the durability requirements in section 4. Any in-ground luminaires, located where vehicles may be active, shall have a maximum surface load capacity of 5,000 kg.

All feature lighting must be circuited and controlled by time clock/ control system to ensure that upward waste light is limited by way of part night switch off. Feature Lighting shall be subject to the following time restrictions:

- Monday to Thursday – Switch on at Dusk, Switch off at 11pm
- Friday to Sunday – Switch on at Dusk, Switch off at 2am (next day)

27. PARKS AND OPEN SPACES

Parks and Open Spaces must adhere to public spaces within AS/NZS 1158 where appropriate. Areas containing feature lighting (e.g., trees, shrubs, or monuments) are covered in Feature Lighting.

28. ILLUMINATED SIGNS

All illuminated signs shall adhere to Section 18, Signs of the Operative and Proposed District Plan. Signs exceeding 150cd/m² of illumination require QLDC consent.

For externally illuminated signs it is preferential that the light source is positioned to point downwards towards the sign rather than upwards to minimise upward light pollution (sky glow). Refer to Feature Lighting for further details.

29. PRIVATE EXTERIOR LIGHTING – NON DOMESTIC

Through the consenting process, QLDC seeks to limit the environmental impact of new artificial lighting by following the general intentions of this document. Private lighting installations contribute to upward waste light and are largely unregulated. The intent of the criteria below is to limit the use uncontrolled luminaires with high colour temperatures used in conjunction with excessive lighting design criteria. The following will apply to any consent application for non-domestic private development with respect to exterior lighting:

- Mandatory use of luminaires with a maximum CCT of 3000k (except Private Sports Fields or by QLDC granted exemption).
- Luminaires used for general area lighting, i.e. safe movement and security shall provide no more than 1% upward waste light ratio as installed.
- Feature lighting (such as building façade and inground luminaires) will require QLDC approval upon application and if granted will be subject to the operating times defined in Section 26.
- Lighting Levels shall be selected based on the Sub-Categories listed in the Tables in Sections 9, 10 and 11 for general area, security, and access lighting.
- Lighting Levels for specific exterior work tasks shall be selected based on (and not exceed) the guidance in AS/NZS 1680.5
- Lighting Levels for private sports fields shall be considered on application by QLDC with detail of the activity being required to assess suitability.
- All lighting must comply with the requirements of AS/NZS 4282.
- Lighting Design Results shall be reasonably close to the Light Technical Parameters utilised in the design to avoid excessive lighting. QLDC reserves the right to instruct any applicant to reduce designed lighting results if they are assessed to be excessive by our consents team or nominated technical review panel.

As part of any new consent application, the applicant must provide a design plan showing the proposed exterior lighting. The Plan and submission shall include the following as a minimum:

- General Site Layout.
- Luminaire Positions and Mounting Heights.
- Luminaire Datasheets for each selected type.
- Clarify Lighting Design Requirements utilised and the Results achieved.
- Show Calculation Results (points and Isolux lines) in a legible format.

QLDC has no interest in assessing the longevity or technical robustness of products selected.

QLDC accepts that some business activities may have bespoke requirements which do not align with some of the above criteria, in this event, it is requested that the applicant provides written justification and details of any proposed departure for QLDC consideration.

30. OUTDOOR DOMESTIC LIGHTING

While the QLDC does not have a vested interest in domestic outdoor lighting installations, there must still be compliance with the District Plan rules.

Glare

- (a) All fixed exterior lighting shall be directed away from the adjacent sites and roads; and
- (b) No activity on any site shall result in greater than a 3.0 lux spill (horizontal and vertical) of light onto any other site measured at any point inside the boundary of the other site.

This document does not cover outdoor domestic lighting, however AS 4282 contains some informative text on good practice including the use of passive infra-red movement detectors or low brightness (dimmed) lighting when continuous (over-night) operation is required.

It is recommended that domestic development follows the criteria listed above for 'Private Exterior Lighting – Non Domestic' in order to assist in the preservation of the dark sky amenity in the region.

31. OPERATIONAL POLICIES

32. STREET LIGHTING RENEWALS

QLDC's policy is to replace decorative poles and luminaires where possible with standard poles and luminaires.

This will not be the case in areas where there are specific design criteria or guidelines such as Arrowtown's Historic Precinct.

33. ATTACHMENTS ON LIGHTING POLES

Any attachment to be placed on to a Lighting Pole must go through an approval process prior to installation, this is to protect the structural integrity of the poles.

Examples of the attachments are as follows, but not limited to:

- Flags and banners

There is existing FlagTrax infrastructure on lighting on Shotover Street, Queenstown and Ardmore Street, Wanaka) which facilitates flags and banners. Please refer to existing 'Banner and Event Signage Policy'.

In special amenity areas such as the town centres or lake front, a decorative cover may be fitted to enable flags or banners. Applications to utilise these flag/banner locations must go through the QLDC Events team.

- Utility attachments such as communications, CCTV, traffic monitoring devices

Contact the QLDC Customer services team in the first instance, this will be referred to the QLDC Operations & Maintenance team for approval on a case-by-case basis and a charge may apply. Application for permanent infrastructure may take the form of a Licence to Occupy (LTO). Details of attachments must be provided as part of the application process.

It is essential that any attachments which connect to the streetlighting power supply must seek approval and provide details of any energy draw. Any such devices found on QLDC lighting infrastructure without written permission, may be removed at Council's discretion.

This does not apply to attachments on lights on the State Highway, please contact Waka Kotahi New Zealand Transport Agency for approval.

34. DATA PROVISION REQUIREMENTS SPECIFIC FOR LIGHTING AND ELECTRICAL INSTALLATIONS

The following documentation shall be provided by the installation contractor following completion:

- As built layout drawings. This can be the design with an 'As-built' statement. This is especially crucial where there is cabling or lighting that cannot be entered onto the RAMM sheet.
- Software design files
- QLDC RAMM Rooding Asset Register (RAMM update sheets) – the latest version can be found on the QLDC website – please always download the latest version as these are being improved <https://www.qldc.govt.nz/services/resource-consents/land-developments-and-subdivisions#code-of-practice>
 - This information shall include column types and luminaire descriptions etc.- The luminaire description shall include make, model, optic, LED count or module size, driver size and power rating e.g. OrangeTek TerraLED Mini 24 AP2 300mA 24W LED.
- Producer statement(s) for all columns installed.
- Luminaire 10-year supplier warranty statement.
- Signed and completed Electrical Certificate of Compliance (CoC) and Electrical Safety Certificate (ESC).
- Signed and completed Record of Inspection (RoI) form.
- Details of any warranties

Note: that the issuing of a 224c certificate (certifying that all subdivision conditions have been met) is conditional upon the electrical installer providing signed CoC/ESC and RoI forms as well as the completed RAMM data.

35. POST CONSTRUCTION REQUIREMENTS

A visual inspection shall be carried out by QLDC to check the following:

- Street lights are livened
- All columns are vertical, and all luminaires are installed with the correct tilt angles and orientation.
- Columns are labelled in accordance with QLDC requirements. Column numbers can be obtained from the QLDC Street Lighting Maintenance Contractor
- A label is attached to the underside of each luminaire describing the optic and wattage e.g., AP2 24W.

DRAFT

APPENDIX 1 - TYPICAL INFORMATION SHEET DRAWING

LUMINAIRE AND POLE LIST

TYPE	LUMINAIRE DESCRIPTION	POLE DESCRIPTION	ARM LENGTH	TILT ANGLE	NO. OFF.
A	ASPECTALB 1151TA 4P 30W/40' 15W LED	SEPARATE TUB SUBSTANTIAL POLE C/W CORRED OUTREACH ARM	3.5	5	10
B	ASPECTALB 1151TA 3P 30W/40' 15W LED	SEPARATE TUB SUBSTANTIAL POLE C/W CORRED OUTREACH ARM	3.5	5	2
C	ASPECTALB 1151TA 2P 30W/40' 15W LED	SEPARATE TUB SUBSTANTIAL POLE C/W CORRED OUTREACH ARM	4.0	5	5
D	ASPECTALB 1151TA 2P 30W/40' 15W LED	SEPARATE TUB SUBSTANTIAL POLE C/W CORRED OUTREACH ARM	4.0	5	4

LEGEND

- NEW LUMINAIRE MOUNTED ON NEW LIGHTING POLE (MOUNTED LUMINAIRE PARTICULAR LUMINAIRE TYPE AND POLE MOUNTING DETAILS AS PER THE LUMINAIRE AND POLE LIST)
- EXISTING LUMINAIRE MOUNTED ON EXISTING LIGHTING POLE
- DOUBLE CONTROLLER LINES

NOTES

- ALL NEW STREET LIGHTING POLES SHALL BE SEPARATE OR QUALITY TREATED OCTAGONAL STEEL TUBULAR CORROSION PLATED COLUMNS COMPLYING WITH INTA 90.
- THE NEW STREET LIGHTING POLES SHALL BE LOCATED IN FRONT OF THE PROPERTY (MOUNTAIN) WITHIN THE ROAD RESERVE OR IN FRONT OF THE PROPERTY (MOUNTAIN) WITHIN THE ROAD RESERVE.
- THE DOUBLE CONTROLLER LINES SHALL BE LOCATED TO COMPLY WITH THE REQUIREMENTS OF AS/NZS 3000 AND THE LOCAL AUTHORITY'S STANDARDS. THE LIGHTING ALONG ROAD TYPICALLY HAS BEEN DESIGNED IN ACCORDANCE WITH THE CATEGORY PA ROAD RESERVE AND THE ROAD LIGHTING ALONG ROAD TYPICALLY HAS BEEN DESIGNED IN ACCORDANCE WITH THE CATEGORY PB ROAD RESERVE. THE LUMINAIRE SHALL BE ASPECTALB LED FOR ROAD WITH PROFILES AND MOUNTING AS LISTED IN THE LUMINAIRE AND POLE LIST.
- THE QUALITY OF MANUFACTURE AND OPTICAL PERFORMANCE OF ANY ALTERNATIVE LED LUMINAIRES SHALL MATCH OR EXCEED THAT OF THE MANUFACTURER AND OPTICAL PERFORMANCE OF ANY ALTERNATIVE LED LUMINAIRES SHALL BE SUBMITTED ALONG WITH ANY ALTERNATIVE LED LUMINAIRE SUBMITTALS.
- WHEN INSTALLING ALL NEW LUMINAIRES SHALL HAVE MOUNTING HEIGHTS, OUTREACH ARM LENGTHS AND TILT ANGLES AS SPECIFIED IN THE LUMINAIRE AND POLE LIST. THIS SHALL BE VERTICAL TO WITHIN 5% WHEN DOUBLE LUMINAIRE IS FITTED IT SHALL HAVE THE FOLLOWING TILT TO WITHIN 5% AND THE AXIS OF THE LUMINAIRE BEAM SHALL BE IN A VERTICAL PLANE TO WITHIN 5%.
- ALL MATERIALS INCLUDING LUMINAIRE, POLES, ARMS AND MOUNTING HARDWARE SHALL COMPLY WITH THE DURABILITY REQUIREMENTS OF THE LOCAL AUTHORITY'S STANDARDS.
- THE CONTRACTOR SHALL BE RESPONSIBLE FOR ANY STREET LIGHTING NETWORK DESIGN AND INSTALLATION THAT MAY BE REQUIRED TO BE INSTALLED AND/OR EXTEND THE SUN AND ALL WORK SHALL BE INSTALLED BY AN EXPERIENCED AND COMPETENT CONTRACTOR.
- THE CONTRACTOR SHALL COMPLY WITH THE ELECTRICAL (SAFETY) REGULATIONS, AS WELL AS ANY OTHER REGULATIONS, AS WELL AS ANY OTHER REGULATIONS AND PROCEDURES. THIS SHALL INCLUDE MAINTAINING THE REQUIRED CLEARANCES BETWEEN POWER LINES AND ANY LIGHTING AND DISTRIBUTIVE EQUIPMENT DURING THE CONSTRUCTION PERIOD AND FOLLOWING COMPLETION WHEN ALL THE LIGHTING EQUIPMENT HAS BEEN INSTALLED.

REFERENCE DRAWINGS

80508565-01-00-L10-03 ROAD LIGHTING LAYOUT SHEETS (T0-0)

CALCULATION RESULTS

Road 1 - Substation Calculation Results for Category PA Lighting (as per AS/NZS 1168.1.1 Table 2.4)		RSL		RSL	
Minimum Spacing (m)	Maximum Spacing (m)	Required	Complete	Required	Complete
15	35	15	35	15	35
Road 2 - Substation Calculation Results for Category PB Lighting (as per AS/NZS 1168.1.1 Table 2.4) <td colspan="2">RSL</td> <td colspan="2">RSL</td>		RSL		RSL	
Minimum Spacing (m)	Maximum Spacing (m)	Required	Complete	Required	Complete
15	35	15	35	15	35
Road 3 - Substation Calculation Results for Category PA Lighting (as per AS/NZS 1168.1.1 Table 2.4) <td colspan="2">RSL</td> <td colspan="2">RSL</td>		RSL		RSL	
Minimum Spacing (m)	Maximum Spacing (m)	Required	Complete	Required	Complete
15	35	15	35	15	35

NOT FOR CONSTRUCTION

WORKING PLOT

ROAD LIGHTING INFORMATION SHEET

Name: A1 SHIRAZ
Scale: 80508565-01-00-L10
Date: A

APPENDIX 2 - TYPICAL DESIGN NOTES AND CALCULATION RESULTS

Drawing Notes (alternative to design report):

NOTES

1. ALL NEW STREET LIGHTING POLES SHALL BE SPUNLITE (OR EQUAL) TAPERED OCTAGONAL STEEL FRANGIBLE GROUND PLANTED COLUMNS COMPLYING WITH NZTA M26.
2. THE NEW STREET LIGHTING POLES SHALL BE LOCATED IN FRONT OF THE PROPERTY BOUNDARIES (WITHIN THE ROAD RESERVE) OR WHERE SHOWN ON THE DRAWINGS.
3. THE ROAD LIGHTING HAS BEEN DESIGNED TO COMPLY WITH THE CATEGORY P REQUIREMENTS OF AS/NZS 1158.3.1 AND THE QLDC SOUTHERN LIGHTS STRATEGY. THE LIGHTING ALONG ROAD 1 (OFF SH6) HAS BEEN DESIGNED IN ACCORDANCE WITH THE CATEGORY P4 REQUIREMENTS AND THE ROAD LIGHTING ALONG THE REMAINING ROADS HAS BEEN DESIGNED IN ACCORDANCE WITH THE CATEGORY P5 REQUIREMENTS. THE PARKING AREA ON ROAD 2 HAS BEEN DESIGNED IN ACCORDANCE WITH THE CATEGORY P11c REQUIREMENTS.
4. THE LUMINAIRES SHALL BE AEC ITALO LEDs (OR EQUAL), WITH MODULES AND WATTAGES AS SPECIFIED IN THE LUMINAIRE AND POLE LIST. THE QUALITY OF MANUFACTURE AND OPTICAL PERFORMANCE OF ANY ALTERNATIVE LED LUMINAIRES SHALL MATCH OR EXCEED THAT OF THE AEC ITALO (INCLUDING THE CURRENT DESIGN SPACINGS) AND SUPPORTING CALCULATIONS SHALL BE SUBMITTED ALONG WITH ANY ALTERNATIVE LUMINAIRES OFFERED.
5. WHEN INSTALLED ALL NEW LUMINAIRES SHALL HAVE MOUNTING HEIGHTS, OUTREACH ARM LENGTHS AND TILT ANGLES AS SPECIFIED IN THE LUMINAIRE AND POLE LIST.
6. WHEN POLES ARE SET IN PLACE THEY SHALL BE VERTICAL TO WITHIN 2°. WHEN EACH LUMINAIRE IS FITTED IT SHALL HAVE THE REQUIRED TILT TO WITHIN 2° AND THE AXIS OF THE LUMINAIRE BEAM SHALL BE IN A VERTICAL PLANE TO WITHIN 2°.
7. ALL MATERIALS (INCLUDING LUMINAIRES, POLES, ARMS AND MOUNTING HARDWARE) SHALL COMPLY WITH THE DURABILITY REQUIREMENTS OF NZTA M26 AND M30.
8. THIS DRAWING ONLY DEPICTS THE LUMINAIRES, POLE LOCATIONS AND MOUNTING REQUIREMENTS ASSOCIATED WITH THE LIGHTING DESIGN. THE CONTRACTOR SHALL BE RESPONSIBLE FOR ANY STREET LIGHTING NETWORK (SLN) DESIGN AND INSTALLATION (THAT MAY BE REQUIRED TO ESTABLISH AND/OR EXTEND THE SLN) AND ALL WORK SHALL BE UNDERTAKEN BY AN EXPERIENCED AND COMPETENT CONTRACTOR "APPROVED" BY THE LOCAL LINES COMPANY.
9. THE CONTRACTOR SHALL COMPLY WITH THE NZ ELECTRICITY (SAFETY) REGULATIONS, NZ WIRING RULES (AS/NZS 3000) AND ANY SPECIFIC LINES COMPANY RULES AND PROCEDURES. THIS SHALL INCLUDE MAINTAINING THE REQUIRED CLEARANCES BETWEEN POWER LINES AND ANY LIGHTING AND CONSTRUCTION EQUIPMENT DURING THE CONSTRUCTION PERIOD AND FOLLOWING COMPLETION WHEN ALL THE LIGHTING EQUIPMENT HAS BEEN INSTALLED.

Illuminance Calculation results (exported from AGI32):

AS/NZS 1158.3.1 Category P - Calculation Summary						
Scene: Scene_1						
Label	CalcType	Units	Avg	Min	Max/Avg	Description
Road 2 Car Parks	Illuminance	Lux	4.23	0.9	2.62	Category P11c - 3.5 Lux (Avg), 0.7 Lux (Min) & Uniformly (Max/Avg) of 10 (Max)
Road 2 LATM 131 L	Illuminance	Lux	N.A.	3.6	N.A.	Category P5 - 3.5 Lux (Min)
Road 2 LATM 131 R	Illuminance	Lux	N.A.	4.0	N.A.	Category P5 - 3.5 Lux (Min)
Road 2 LATM 149 L	Illuminance	Lux	N.A.	4.2	N.A.	Category P5 - 3.5 Lux (Min)
Road 2 LATM 149 R	Illuminance	Lux	N.A.	4.1	N.A.	Category P5 - 3.5 Lux (Min)
Road 3 LATM 139 L	Illuminance	Lux	N.A.	4.6	N.A.	Category P5 - 3.5 Lux (Min)
Road 3 LATM 139 R	Illuminance	Lux	N.A.	4.1	N.A.	Category P5 - 3.5 Lux (Min)
Road 4 LATM 161 L	Illuminance	Lux	N.A.	4.1	N.A.	Category P5 - 3.5 Lux (Min)
Road 4 LATM 161 R	Illuminance	Lux	N.A.	4.5	N.A.	Category P5 - 3.5 Lux (Min)

APPENDIX 3 – LIGHTING COLUMN POWER SUPPLY AND ELECTRICAL DETAILS

Appendix 3.1 Typical Wiring showing Ownership Boundaries

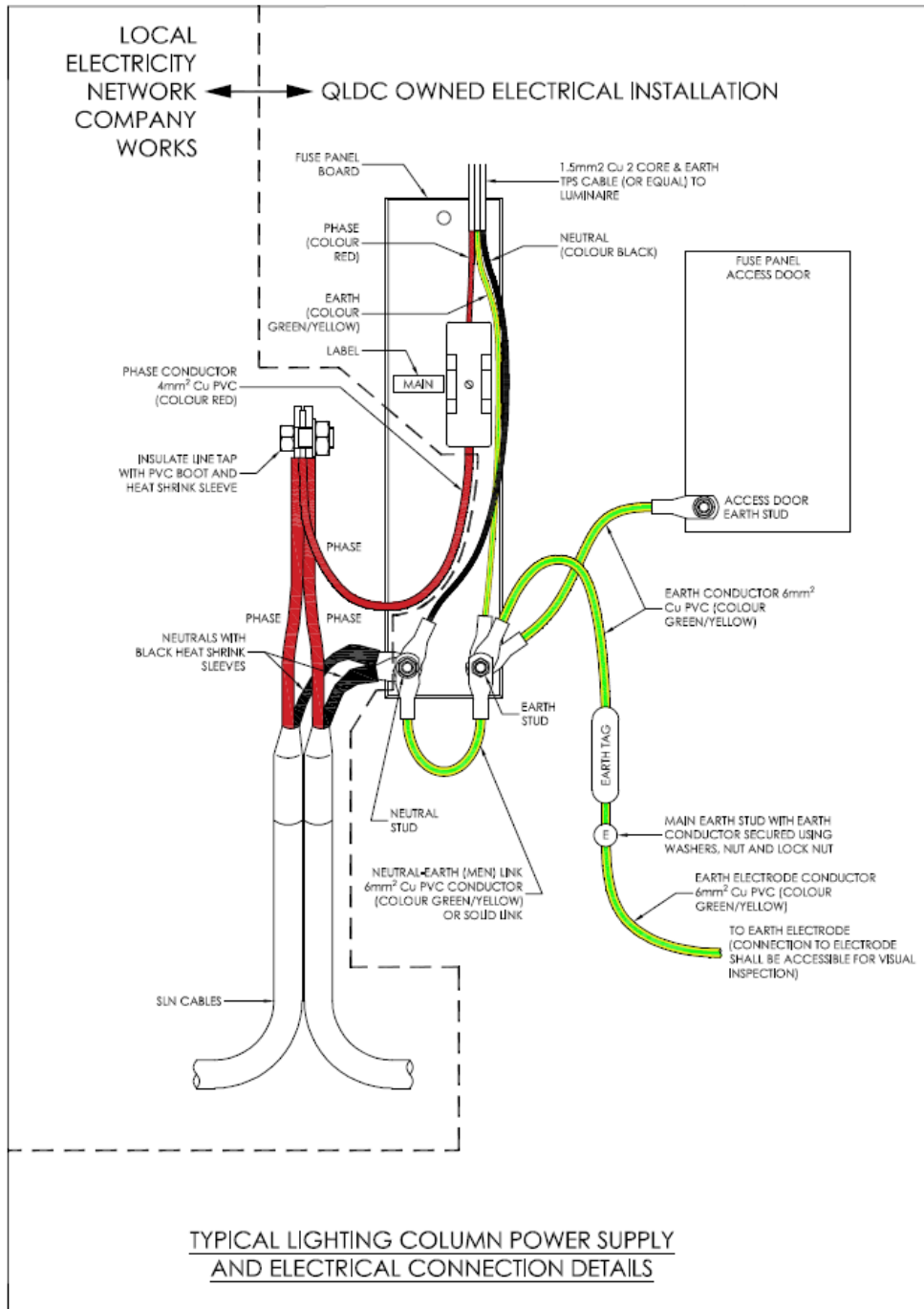

Appendix 3.2 - Street Light FD150 Cutout Assembly

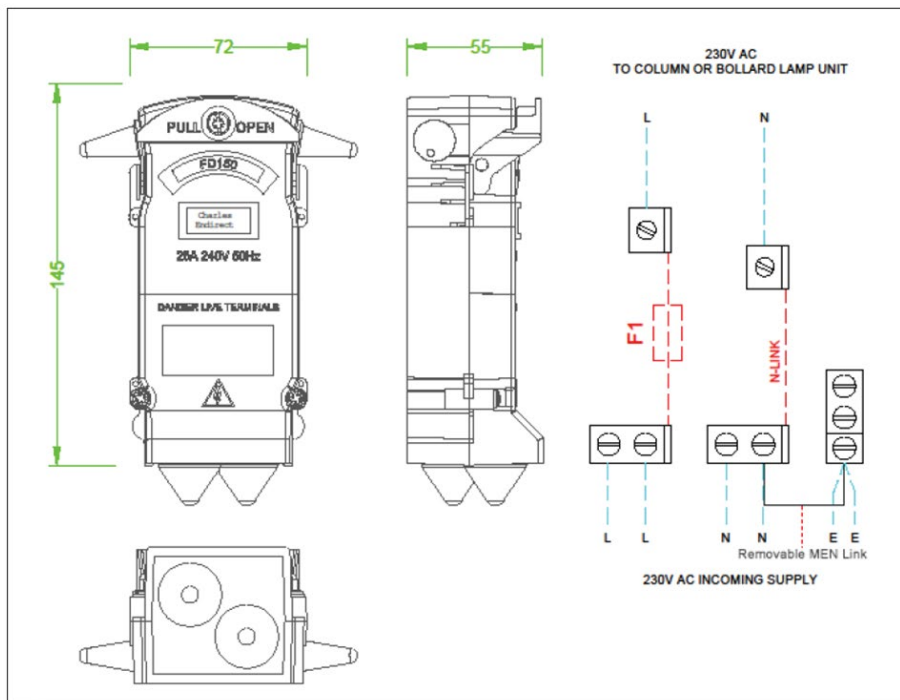
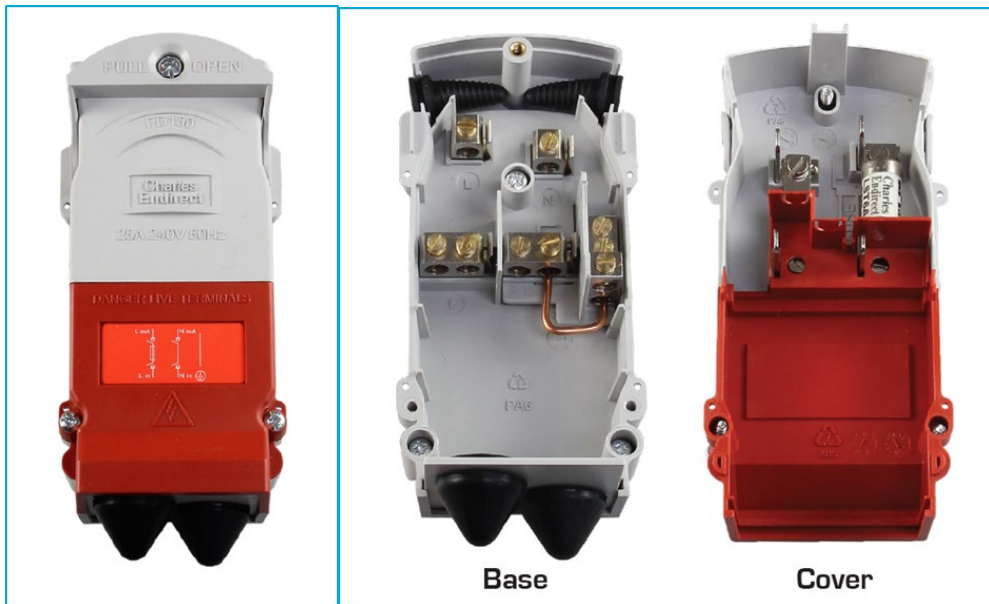

Appendix - 3.3 Fused Street Light Board



Appendix 3.4 Typical Earth Rod Inspection Pit

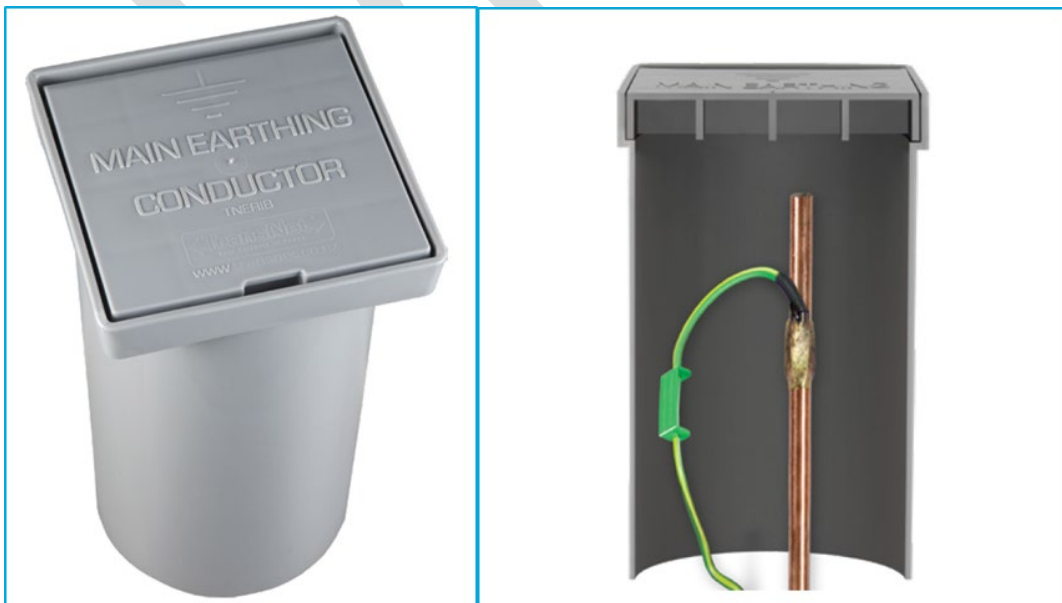

APPENDIX 4 - TYPICAL LAYOUT DRAWING

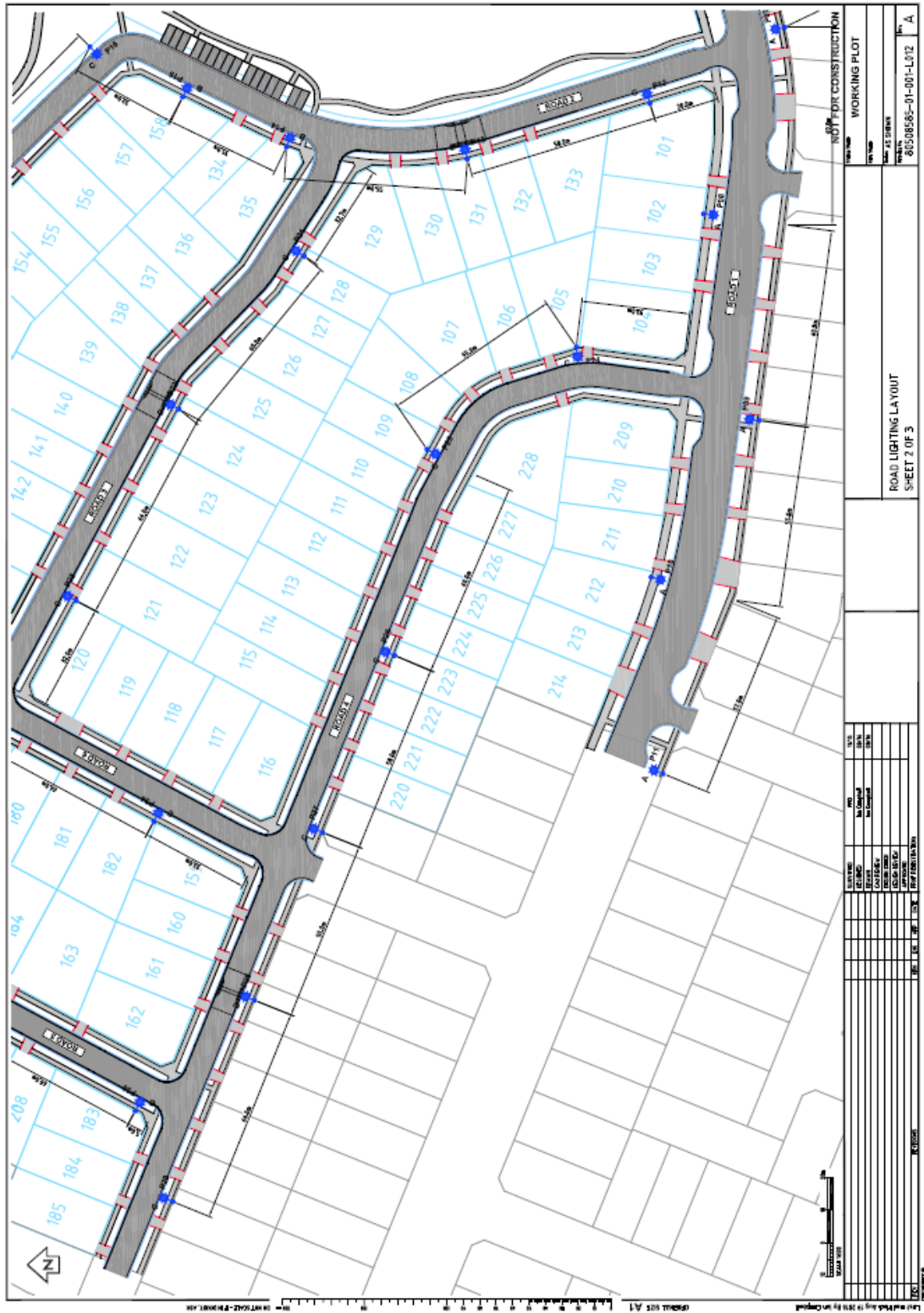

APPENDIX 5 - TYPICAL PERFECT LITE CALCULATION RESULTS

Road 1_P4_SS 42m_7.5+2+5_Italo 1 STA 525mA 54W

P Category Lighting - AS/NZS 1158.3.1:2005

I-table Filename: C:\Data\Road Lighting\Photometric Files\AEC\Italo Range 2015-08-20\Italo 1\ITALO 1 OF2 STA 4.5-4M.cie

Job Name: Hanley Downs DP1 - Road 1

Luminaire Description: IT1 OF2 STA 5-4M 5440 lms
 Lamp Wattage & Type: 54W
 Initial Lamp Flux: 5440 lms
 Maintenance Factor: 0.8
 Stores Code:
 Upcast Angle: 5 degrees
 Arrangement: Single Side
 Offset Distance: 2.56 m
 Upward Waste Light Ratio: .0 %
 Light Source: LED - Light Emitting Diode
 Luminaire Classification: Not specified

Lighting Category: P4 (Local Area Roads - Tables 2.1 & 2.6)

Illuminance Criteria: Average Illuminance (Eav) \geq 0.85 lx
 (Maintained values) Minimum Illuminance (Eph) \geq 0.14 lx
 Illuminance Uniformity (Up) \leq 10

Calculation Grid: 20 x 11 points - Figure 3.7 of AS/NZS 1158.2

@B Mounting @B Height @B -----	Maximum Spacing for different Road Reserve Widths -----
25.0 +-----+	
7.5 42.6 +-----+	

Value/s in above table are all in metres.
 The table contains maximum spacings which, for the specified luminaire and lamp combination, provide compliance with the light technical parameters (LTPs) of Table 2.6 of AS/NZS 1158.3.1:2005.

Refer next page for list of LTP's at compliant maximum spacings.

 @IPlePcat - Vers 3.09 (Built: 18/10/12) Run: 16/ 8/2016 at 16:38:41

Light Technical Parameters at Maximum Spacing

Mounting Height (m)	Road Reserve (m)	Maximum Spacing (m)	Eav (lx)	Eph (lx)	Up (E _{max} /E _{av})	E _{max} (lx)
7.5	25.0	42.6	3.37	0.14	6	20.42

 @IPlePcat - Vers 3.09 (Built: 18/10/12) Run: 16/ 8/2016 at 16:38:41

APPENDIX 6 - TYPICAL POLE DETAILS

6.1 TAPERED OCTAGONAL STEEL LIGHTING POLE C/W CURVED OUTREACH ARM

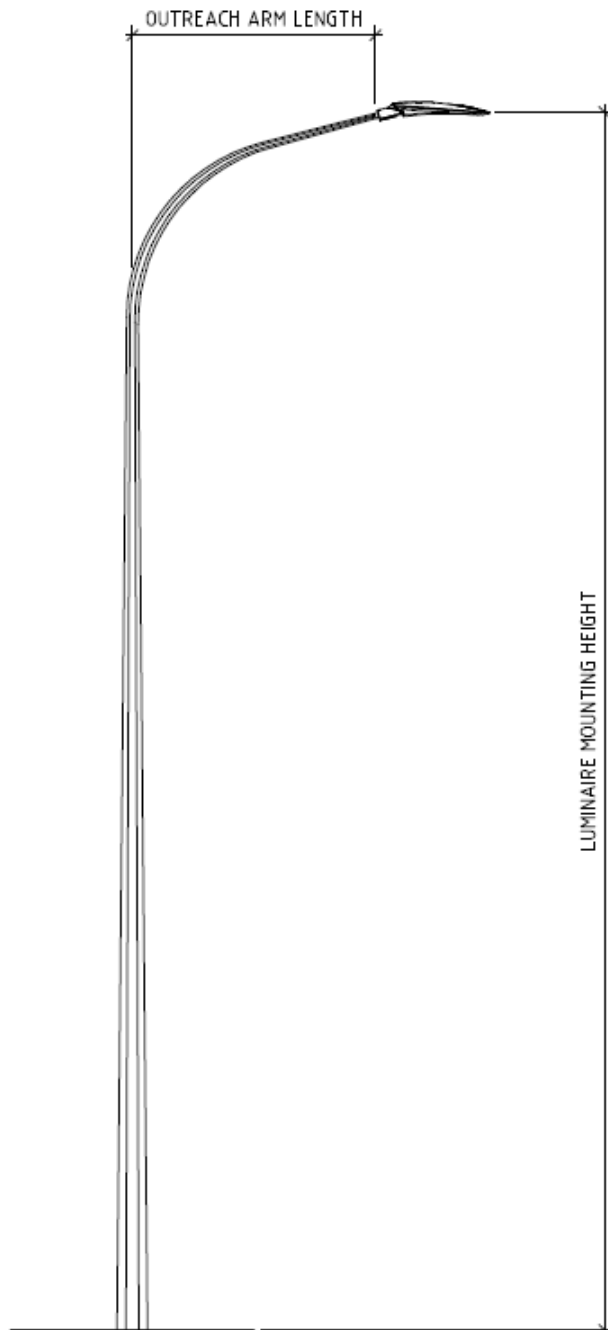

6.2 TYPICAL LIGHTING POLE FOUNDATION DETAILS

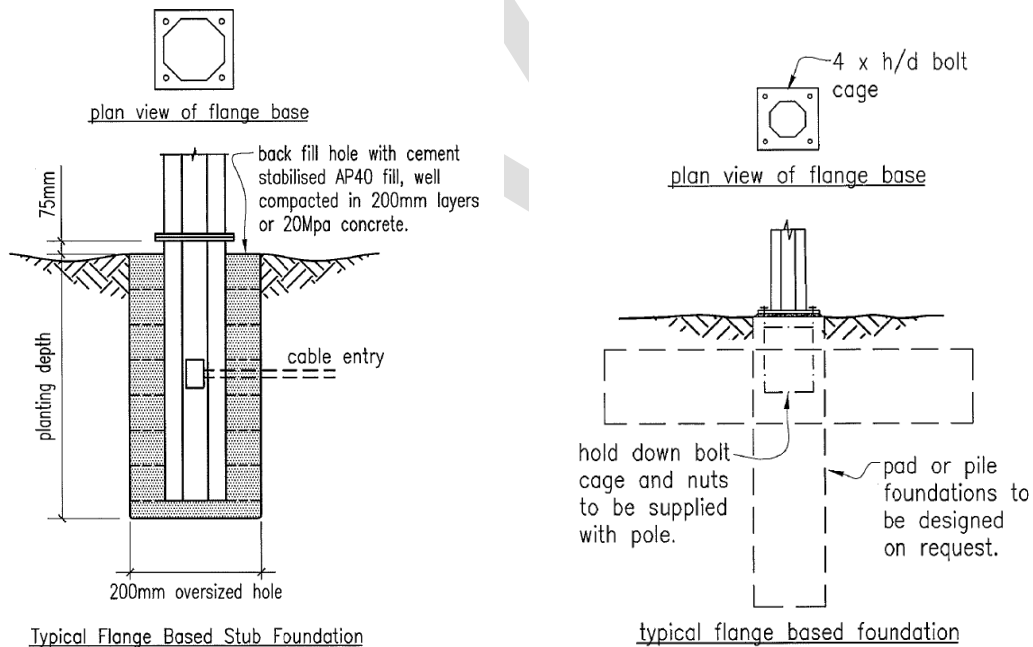
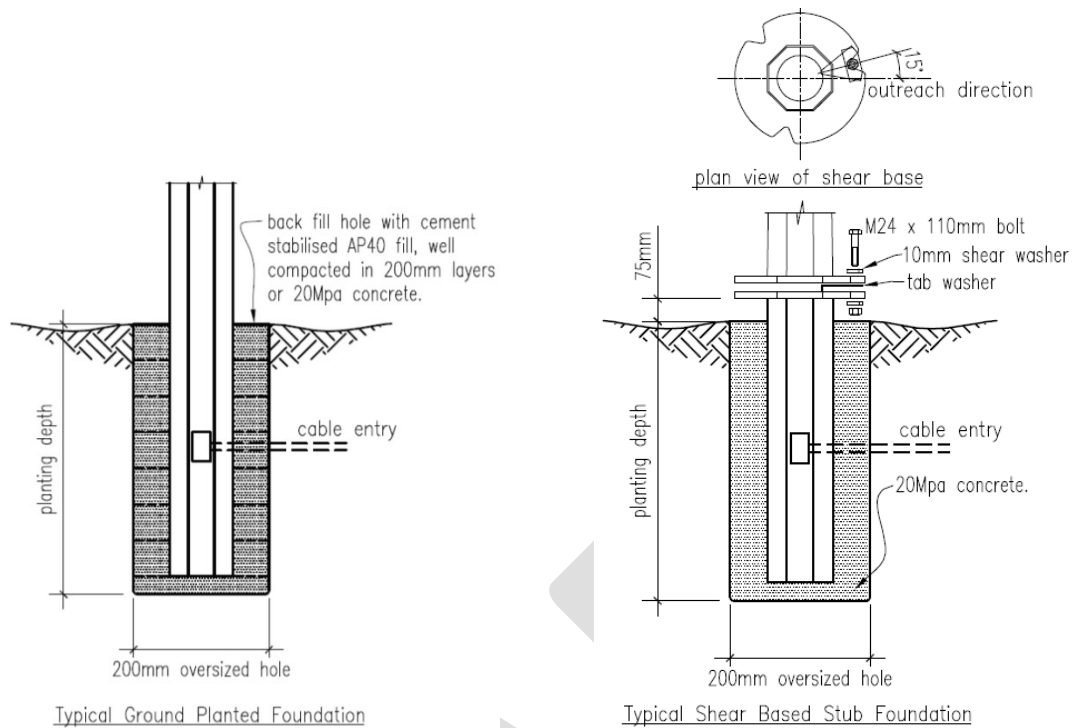

Note: The above arrangements depict typical details only and the actual mounting details may vary between pole suppliers. Specific design may also be required due to site specific ground conditions.

6.3 JUMA AND JUSP SIGNAL POLES

JUMA Signal Pole:

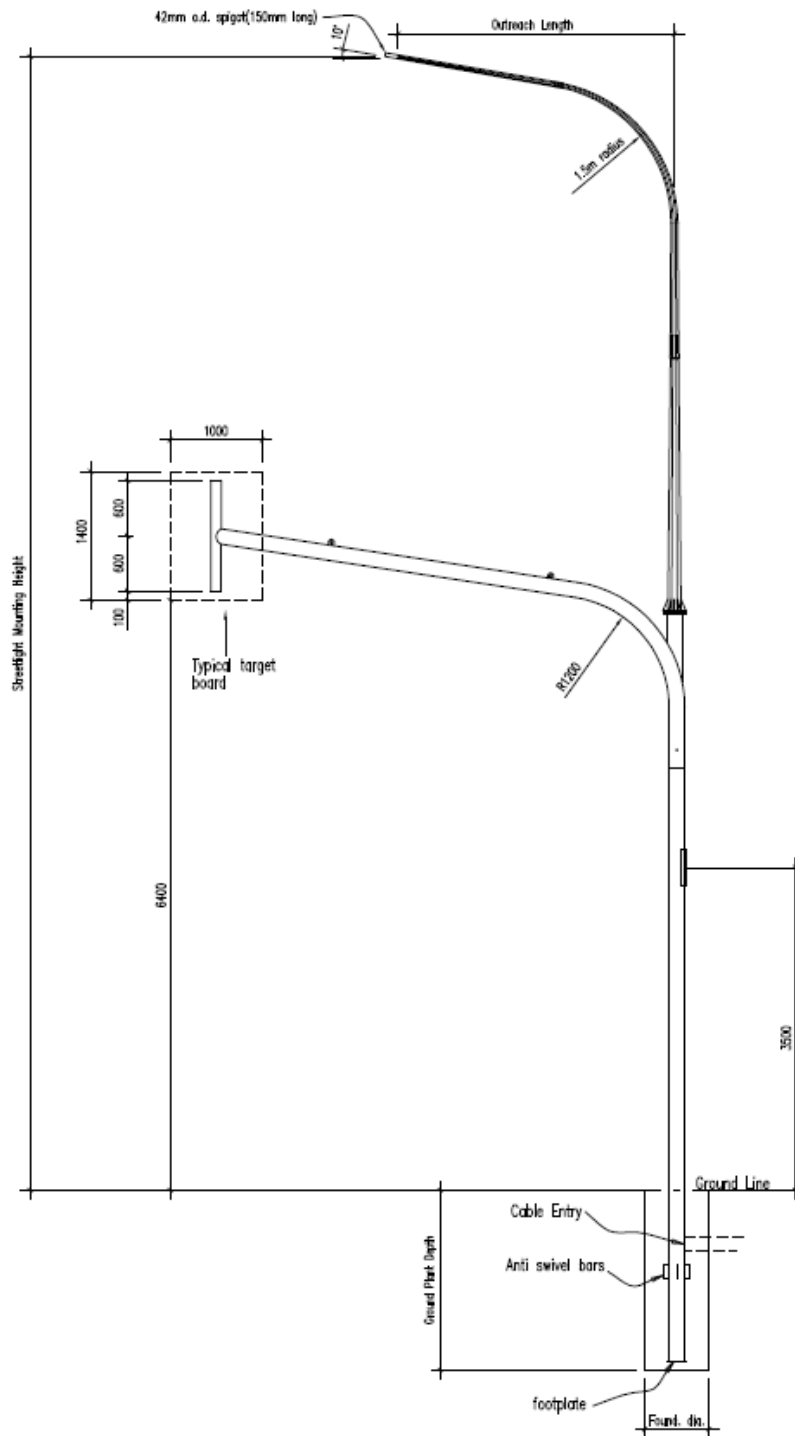

JUSP SIGNAL POLE:

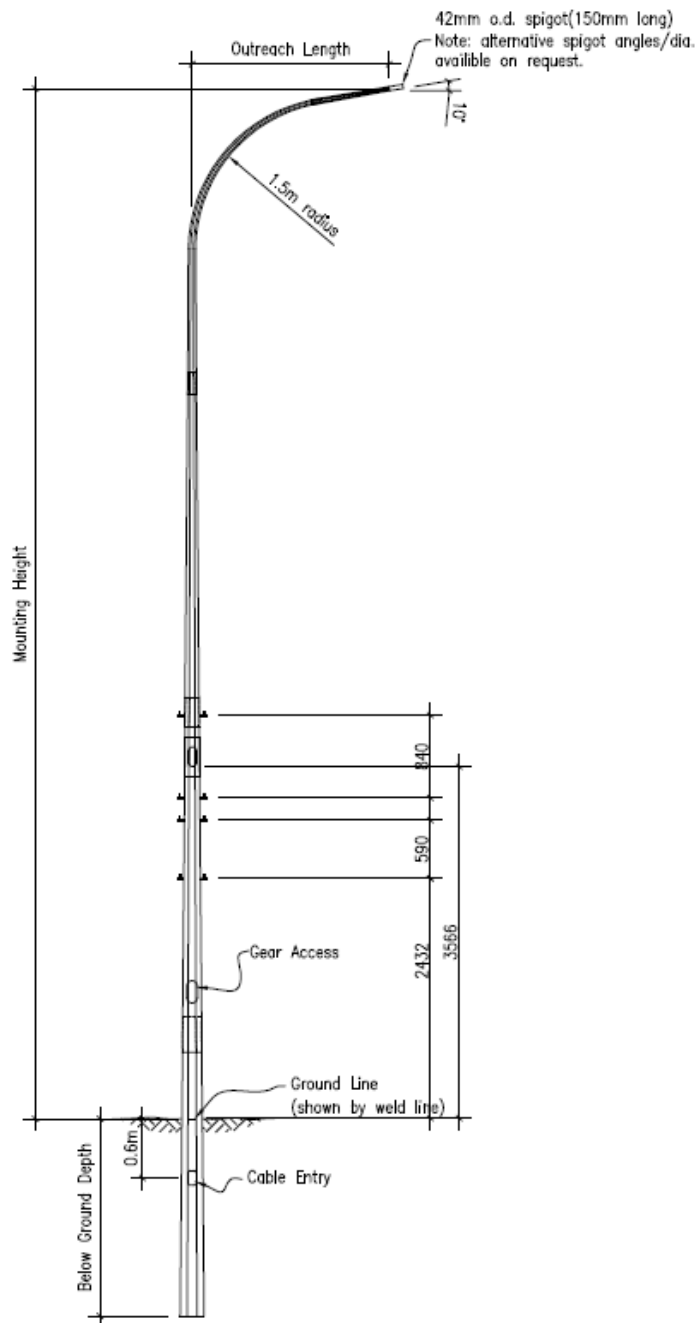

6.4 TYPICAL POWER POLE MOUNTING DETAILS

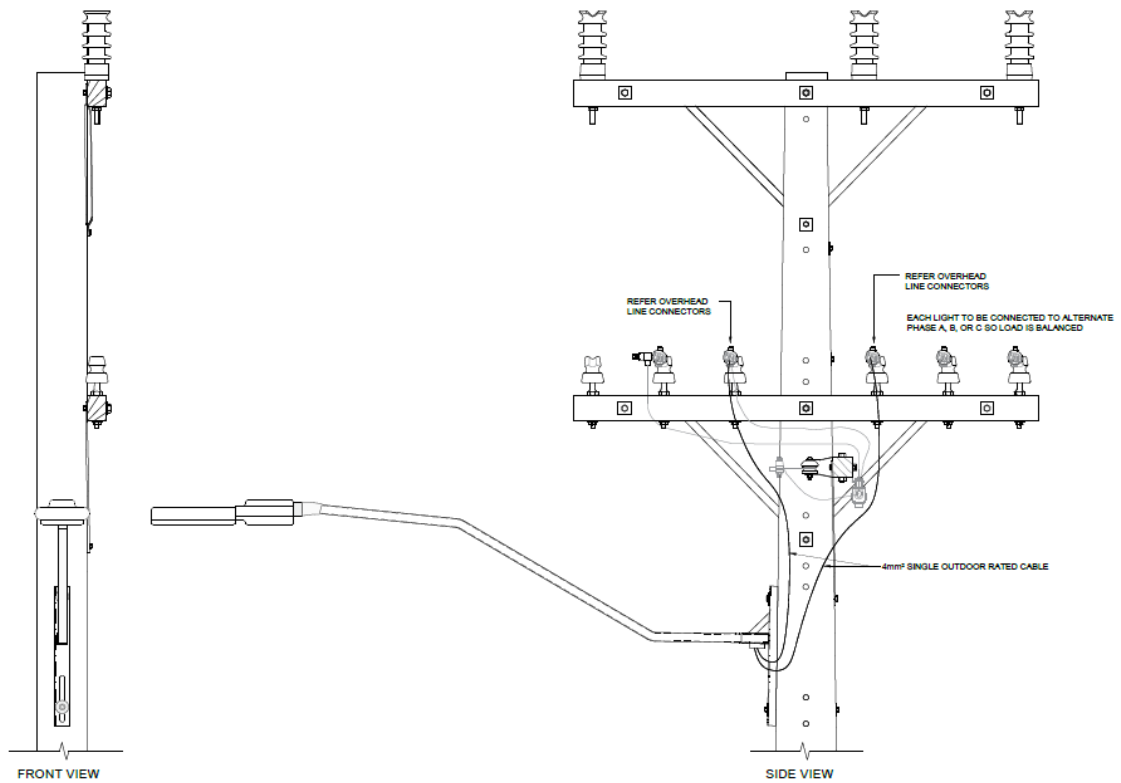

Note: The above arrangement is typical only and any work on or near overhead lines shall be undertaken by the local electricity network company or a contractor approved by the local electricity network company.

APPENDIX 7 - EXAMPLE OF COMMUNITY SPECIFIC DESIGN (CARDRONA)

The following images have been presented as an example of a community specific design that was applied to a lighting upgrade at Cardrona where equipment (luminaires and poles) were selected to blend in with the historical context of the Cardrona Hotel and surrounding environment.

Image date December 2009 (before upgrade):



Image date July 2015 (after upgrade):



APPENDIX 8 – EXAMPLE FORMS

8.1 ELECTRICAL COC AND ESC FORM

ELECTRICAL CERTIFICATE OF COMPLIANCE & ELECTRICAL SAFETY CERTIFICATE																	
 REFERENCE/CERTIFICATE ID No.: <input type="text"/>																	
<small>This form has been designed to be used by licensed electrical workers to certify that installations or Part installations under Part 1 or Part 2 of AS/NZS 3000 are safe to be connected to the specified system of electrical supply.</small>																	
Location Details: <input type="text"/>																	
Contact Details: (Name and address) <input type="text"/>																	
Name of Electrical worker: <input type="text"/>	Registration/Practising licence number: <input type="text"/>																
Phone & email: <input type="text"/>																	
Name and registration number of person(s) supervised: <input type="text"/>																	
Certificate of Compliance																	
Type of work: <input type="checkbox"/> Addition <input type="checkbox"/> Alteration <input type="checkbox"/> New work <input type="checkbox"/> Low risk <input type="checkbox"/> General <input type="checkbox"/> High-risk (Specify): <input type="text"/>																	
The prescribed electrical work is: <input type="checkbox"/> Part 1 of AS/NZS 3000 <input type="checkbox"/> Part 2 of AS/NZS 3000																	
Additional Standards or electrical code of practice were required: <input type="checkbox"/> No <input type="checkbox"/> Yes (specify): <input type="text"/>																	
Date or range of dates that prescribed electrical work undertaken: <input type="text"/>																	
Contains fittings that are safe to connect to a power supply? <input type="checkbox"/> Yes <input type="checkbox"/> No																	
Specify type of supply system: <input type="text"/>																	
The installation has an earthing system that is correctly rated (where applicable) <input type="checkbox"/> Yes <input type="checkbox"/> No																	
Parts of the installation to which this certificate relates that are safe to connect to a power supply?																	
<input type="checkbox"/> All <input type="checkbox"/> Parts (specify) <input type="text"/>																	
The work relies on manufacturers instructions: <input type="checkbox"/> Yes <input type="checkbox"/> No																	
<small>If yes – identify the instruction manual including name, date and version. Also attach a copy of manufacturer's instructions to this certificate. (Or provide reference to readily accessible electronic format, eg Internet link.)</small>																	
Identify: <input type="text"/>																	
Link: <input type="text"/>																	
The work has been done in accordance with a certified design: <input type="checkbox"/> Yes <input type="checkbox"/> No																	
<small>If yes – identify the certified design including name, date and version. Also attach a copy of the certified design to this certificate. (Or provide reference to readily accessible electronic format, eg Internet link.)</small>																	
Identify: <input type="text"/>																	
Link: <input type="text"/>																	
The work relies on a Supplier Declaration of Conformity (SDoC): <input type="checkbox"/> Yes <input type="checkbox"/> No																	
<small>If yes - identify the SDoC including name, date and version OR EESS registration. Also attach a copy of the SDoC to this certificate. (Or provide reference to readily accessible electronic format, eg Internet link.)</small>																	
Identify: <input type="text"/>																	
Link: <input type="text"/>																	
The installation has been satisfactorily tested in accordance with the Electricity (Safety) Regulations 2010 <input type="checkbox"/> No <input type="checkbox"/> Yes																	
Description of Work: <input type="text"/>	<table border="1"> <thead> <tr> <th colspan="2">Test Results (provide values)</th> </tr> </thead> <tbody> <tr> <td>Polarity</td> <td></td> </tr> <tr> <td>(Independent earth):</td> <td></td> </tr> <tr> <td>Insulation resistance:</td> <td>Ohms</td> </tr> <tr> <td>Earth Continuity:</td> <td>Ohms</td> </tr> <tr> <td>Bonding:</td> <td>Ohms</td> </tr> <tr> <td>Fault Loop impedance:</td> <td>Ohms</td> </tr> <tr> <td>Other (specify):</td> <td></td> </tr> </tbody> </table>	Test Results (provide values)		Polarity		(Independent earth):		Insulation resistance:	Ohms	Earth Continuity:	Ohms	Bonding:	Ohms	Fault Loop impedance:	Ohms	Other (specify):	
Test Results (provide values)																	
Polarity																	
(Independent earth):																	
Insulation resistance:	Ohms																
Earth Continuity:	Ohms																
Bonding:	Ohms																
Fault Loop impedance:	Ohms																
Other (specify):																	
By signing this document I certify that the completed prescribed electrical work to which this Certificate of Compliance applies has been done lawfully and safely, and the information in the certificate is correct.																	
Certifier's signature: <input type="text"/>	Date: <input type="text"/>																
Electrical Safety Certificate																	
By signing this document I certify that the installation, or part of the installation, to which this Electrical Safety Certificate applies is connected to a power supply and is safe to use.																	
Certifier's name: <input type="text"/>	Registration/Practising licence number: <input type="text"/>																
Certifier's signature: <input type="text"/>	Connection Date: <input type="text"/>																
Certificate Issue Date: <input type="text"/>																	
<small>CUSTOMER COPY – THIS IS AN IMPORTANT DOCUMENT AND SHOULD BE RETAINED FOR A MINIMUM OF 7 YEARS</small>																	
<small>This Electrical Safety Certificate also confirms that the electrical work complies with the building code for the purposes of Section 18(1)(a) of the Building Act 2004.</small>																	

8.2 ELECTRICAL ROI FORM



RECORD OF INSPECTION (ROI) OF HIGH- RISK PRESCRIBED ELECTRICAL WORK
PURSUANT TO THE ELECTRICITY (SAFETY) REGULATIONS 2010

Reference/Record ID Number:

Issuer (Inspector) details:

Name of Inspector: Registration #:
Email address: Telephone:

Location of installation:

Location details:
Location type: Domestic Non-Domestic Accommodation Industrial Commercial
 Educational Healthcare Miscellaneous (other)

Certifying Electrical Work and Certificate of Compliance (CoC) details:

Name of Electrical worker(s): Registration #:
CoC details: CoC(s) attached

Certifying Electrical Work and Rol details:

What was inspected:

Specify the regulation(s) and companion standard(s), or identify the certified design, followed when carrying out the inspection:

What are the results of the inspection:

High Risk Category:

Not to AS/NZS 3000 Part 2 – 6A(2)(a)(i) Photovoltaic system – 6A(2)(a)(iv) Electrical medical area – 6A(2)(a)(vi)
 High voltage installation – 6A(2)(a)(ii) Hazardous area – 6A(2)(a)(v) Mains work – 6A(2)(b)
 Mains parallel generation – 6A(2)(a)(iii) Animal stunning or meat conditioning – 6A(2)(c)
 Other – please describe:

Declaration

I hereby confirm that the work described above has been done in accordance with the regulations; and the installation on which the work has been done is, and will be, when energised, electrically safe.

Signature: Date:

Record of Inspection (Rol) – Version: May 2014